

The FastJack® 2x Bracket is a connection “splice” which allows 2 support rails to be mounted on a single FastJack®. This bracket minimizes the number of needed FastJacks® by 25%.

Recommended for sloped roof-tops only. Please note that only 2 rows at a time can use a common row of connections. The space between support rails should not exceed 48”.

SPECIFICATIONS

Materials: Tumbled aluminum & stainless steel hardware

Product

Integration: RoofTrac® w/ FastJack®

Order #s: A-FJT-20

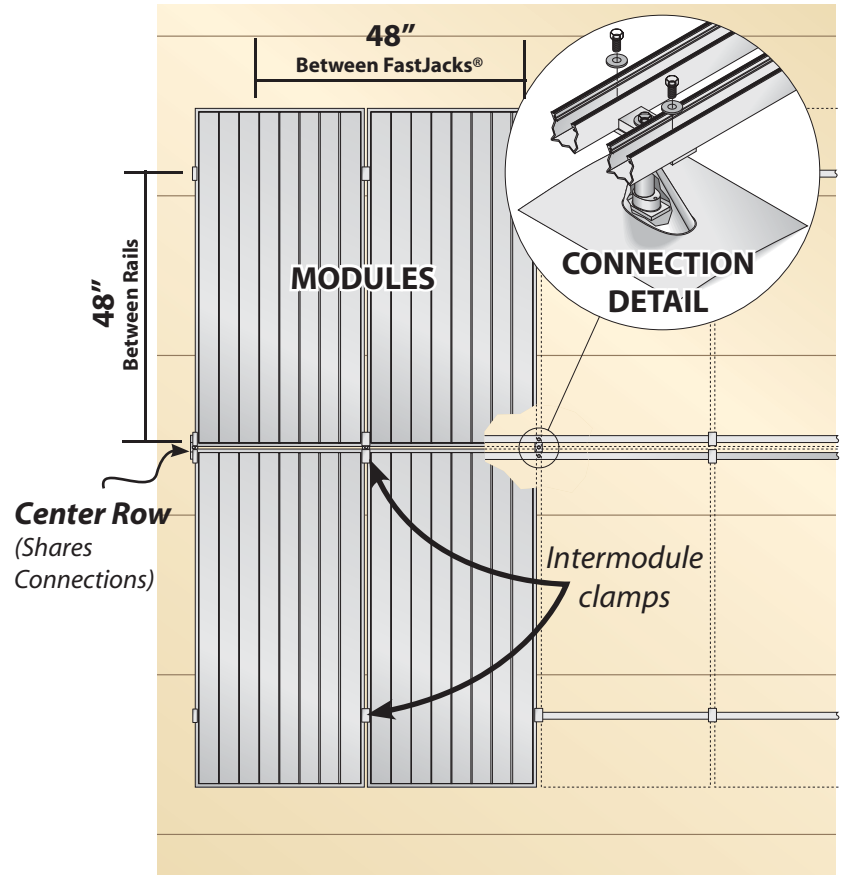

2x Bracket



3/8" X 1-1/4"
SS Hex Bolt



3/8" X 1/2" SS
Hex Bolts





3/8" SS Flat
Washers

Per Box:

- (20) Tumbled aluminum 2x Brackets
- (20) 3/8" x 1-1/4" SS Hex Bolts
- (40) 3/8" x 1/2" SS Hex Bolt
- (60) 3/8" SS Flat Washers



(800) 967-6917

www.dcpower-systems.com