

Model DC210-12

(210AH/12 Volt)

BCI Group: 4D



DEEP CYCLE SERIES



CONSTANT CURRENT DISCHARGE (Amps)

CUT OFF VOLTAGE V/cell	30M	45M	1H	2H	3H	5H	8H	10H	12H	20H	24H
1.75V	195.3	143.9	115.8	64.3	47.6	33.3	22.9	18.9	16.1	10.5	8.8

CRANKING PERFORMANCE

CA 32°F	CCA 0°F
1425	1180

RESERVE CAPACITY

@25 AMPS	@75 AMPS
400 Minutes	105 Minutes

SPECIFICATIONS

Nominal Voltage		12 Volt
Rated Capacity (20 hour rate)		210 AH
Dimensions	Total Height (including terminals)	239 mm (9.41")
	Height	214 mm (8.43")
	Length	530 mm (20.87")
	Width	209 mm (8.23")
Weight		60.5 kg (133.1 lbs)

CHARACTERISTICS

Capacity 77°F (25°C)	20 Hour Rate (10.5A to 10.5 Volts)	210AH
	10 Hour Rate (18.9A to 10.5 Volts)	189AH
	5 Hour Rate (34.4A to 10.2 Volts)	172AH
Internal Resistance	Full charged Battery 77°F (25°C)	2.3m Ω
Capacity Affected by Temperature (20 Hour Rate)	104°F (40°C)	102%
	77°F (25°C)	100%
	32°F (0°C)	85%
	5°F (-15°C)	65%
Self-Discharge 77°F (25°C)	Capacity after 3 month storage	91%
	Capacity after 6 month storage	82%
	Capacity after 12 month storage	64%
Max. Discharge Current 77°F (25°C)	2000A (5s)	
Terminal Standard	L Terminal (LT)	
Charging (Constant Voltage)	Cycle	Initial Charging Current $\leq 0.2 \times C20$ 14.5V ~ 14.9V/77°F (25°C)
	Float	13.6V ~ 13.8V/77°F (25°C)

DISCHARGE CHARACTERISTICS

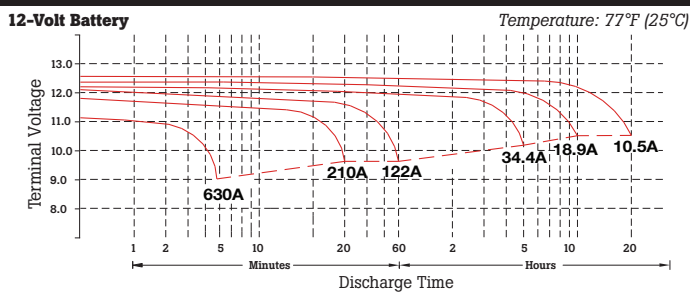

SIZE & DETAILED ILLUSTRATION

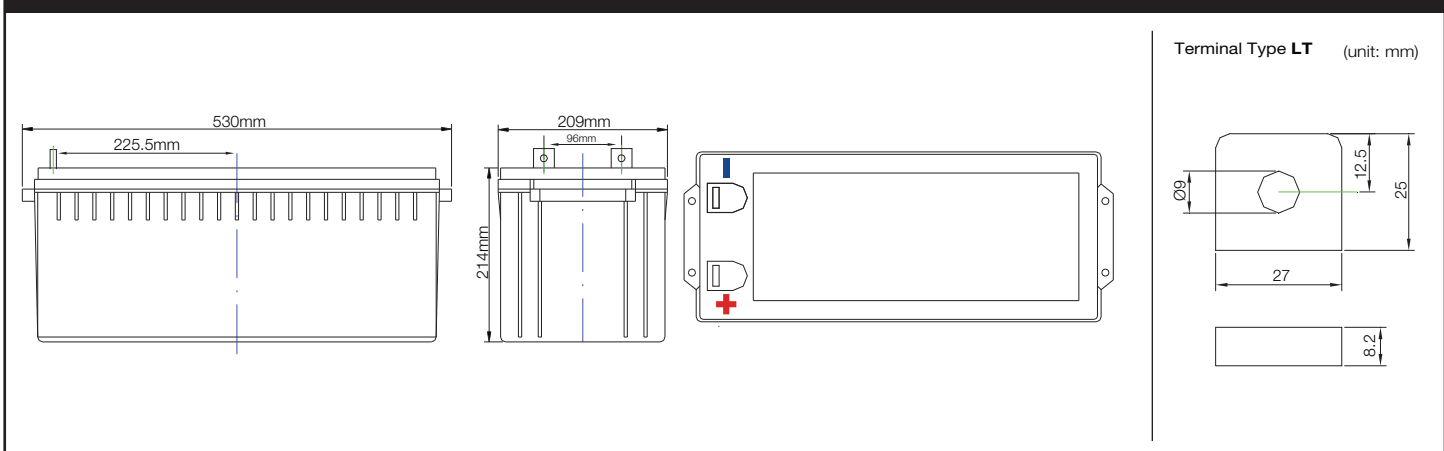

This information is generally descriptive only and is not intended to make or imply any representation, guarantee or warranty with respect to any cells and batteries. Cell and battery designs/specifications are subject to modifications without notice. Contact Fullriver for the latest information.