

The Splice Kit integrates with the RoofTrac® support rail to allow shorter lengths of rail to be handled as one section. A benefit of the splice kit is that it allows for thermal expansion of the aluminum while keeping the support rail from changing position during the process.

SPECIFICATIONS

Materials: Anodized Aluminum Lower support, tumbled aluminum inner support & stainless hardware

Product Integration: RoofTrac® & SolarWedge®

Order #: A-SPLICE-20

IMPORTANT: Maximum 3 support rails in a consecutive row.

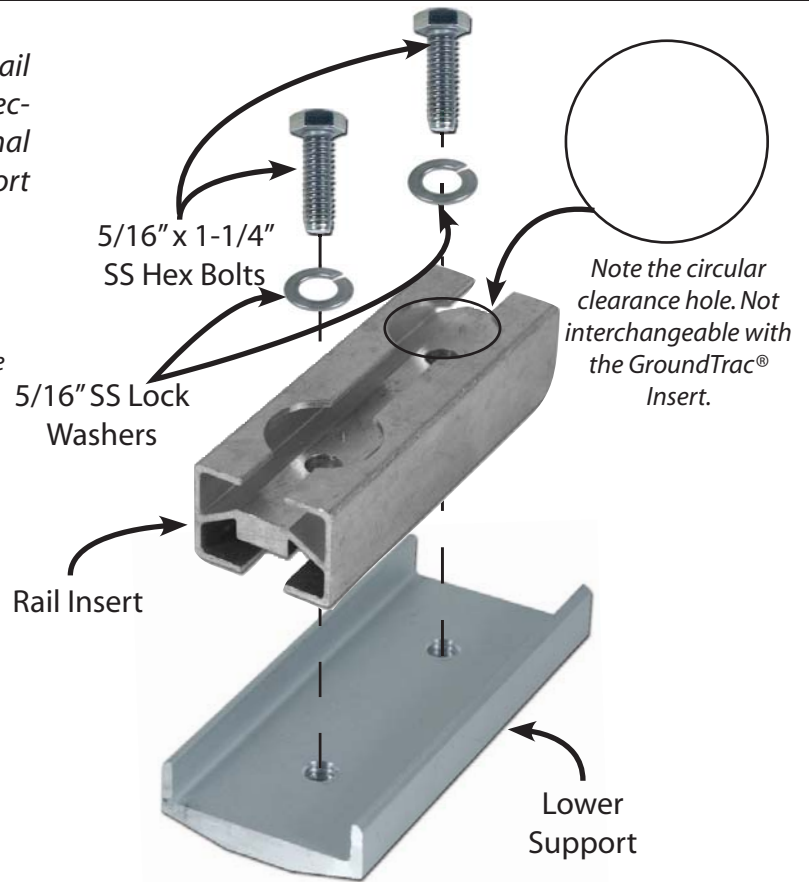

INCLUDED PARTS

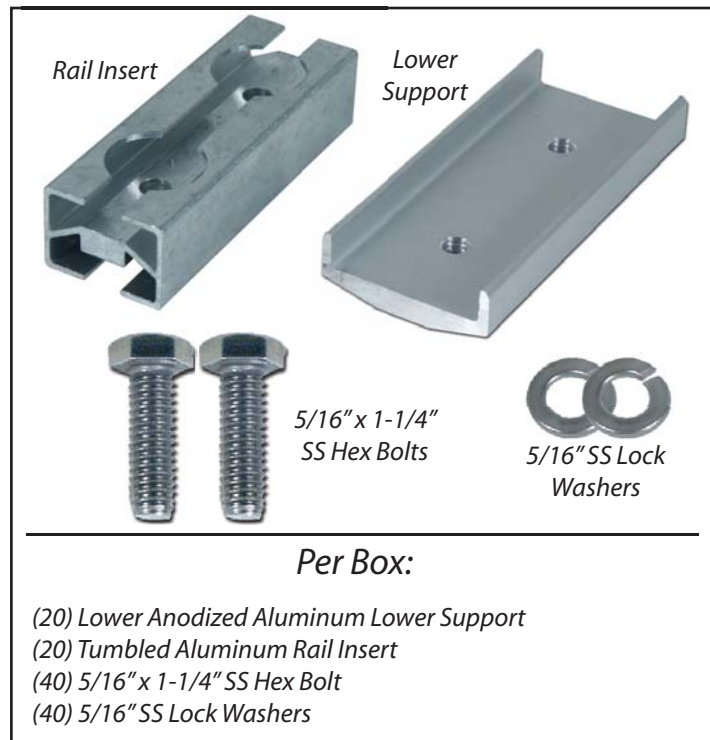

INSTALLED SPLICE

