

**SERIES 120-6 TOP-OF-POLE MOUNT
INSTALLATION INSTRUCTIONS**

Designed to hold up to 120 Sq. Ft. of solar modules
and to mount on a 6" SCH 40 Pole

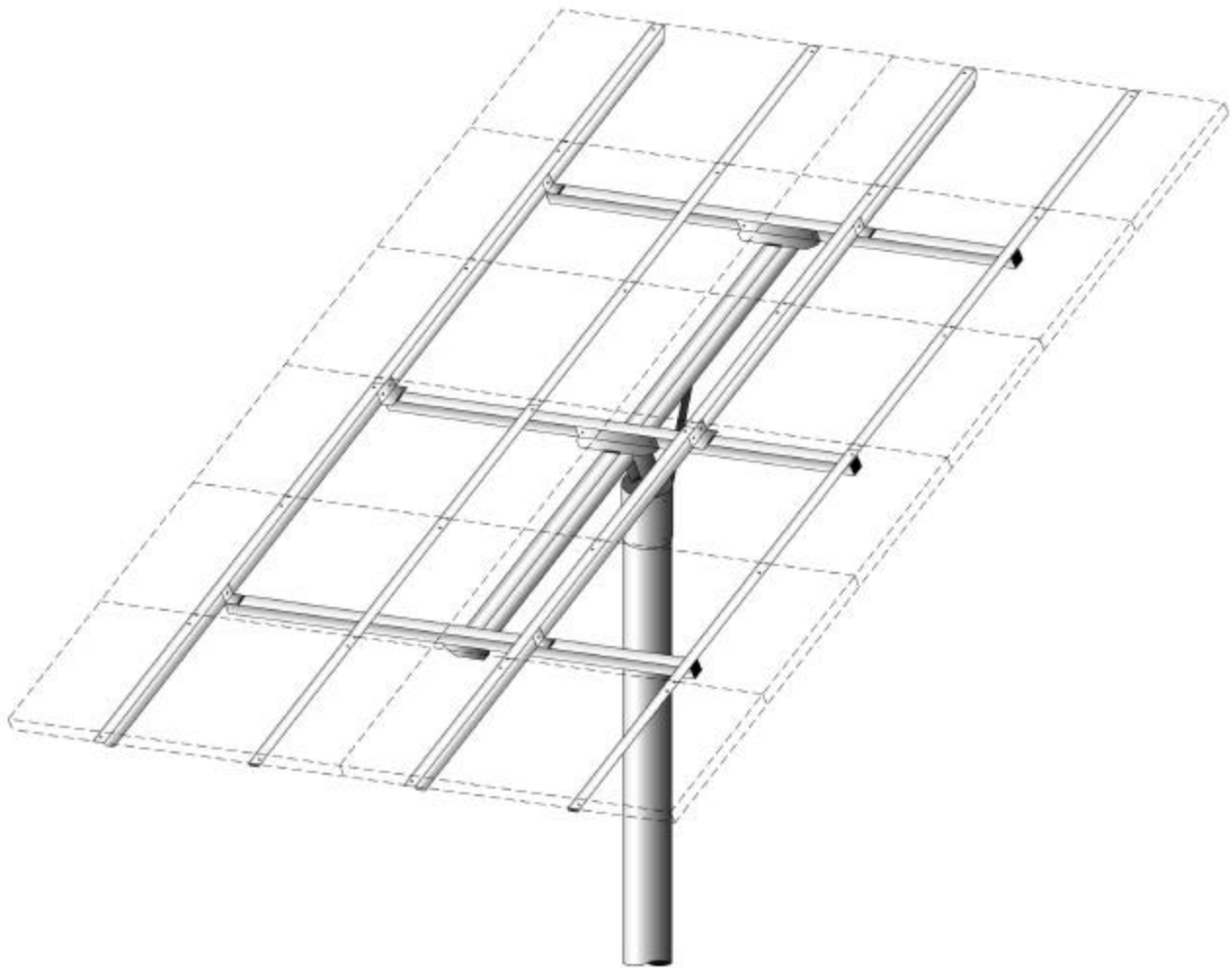

SERIES 120-6 Rack

First a word on our product:

The Series 120-6 does not denote the specific number of modules to be mounted but rather the overall size of the array. The Series 120-6 is designed to hold up 120 square feet of modules and the rack mounts on a 6" Schedule 40 steel pole. Like any of our Series designations there are several Models that fall within the Series. The drawing on the front page may or may not depict the exact number of solar modules you have to mount on your structure. The drawing depicts 12 modules that are approximately 26"x 52" each for a total area of 113 square feet. The Model # depicts the number of models to be mounted. For example, the TPM12-SM110 holds twelve Shell 110 watt modules.

Components:

- 1ea. Strongback with Support-Bar
- 1ea. Mounting Sleeve with Pivot Bolt
- 3ea. Cross-Bars (2" square tubing with 4 pcs. of angle welded to it)
- 8ea. Module Rails - 2"x2" angle
- 1 lot rack assembly hardware
 - 6 - 3/8" x 3" Bolts
 - 16 - 3/8" x 1" Bolts
 - 16 - 3/8" Lock Washers
 - 44 - 3/8" Flat Washers
 - 22 - 3/8" Nuts
- 1 lot 1/4" module mounting hardware
 - 4 Bolts, Lock Washers, and Nuts per solar module
 - 8 Flat Washers per solar module

INSTALLATION INSTRUCTIONS

Please read the instructions completely before assembling the rack. Reading these instructions may prove to save you time in the assembly process

Mounting Pole Installation

You will need a piece of 6" SCH40 steel pipe (6-5/8" OD) for a mounting pole. This piece of pipe should be 13-14 feet long. Dig a hole 24"-30" in diameter and 60" to 84" deep. A Sonotube concrete form may be used to provide for a clean installation. After placing the pole into the ground route the necessary electrical conduits to the pole. Fill the hole concrete to the top. Plumb the pole and brace it until the concrete hardens (at least 48 hours). If you live in an area with deep snow build-up you may want a taller pole. For every extra foot above ground you must have at least 8" more in the ground in concrete.

NOTE:

Refer to the foundation and assembly drawings on the following pages for assembly details. It is the installer's responsibility to ensure that the pole and structure are installed correctly. If in doubt regarding the soil type or other variables in the concrete foundation requirements consult a local engineer.

Mounting Structure Installation

1. Bolt the Mounting Sleeve to the Strongback and attach the free end of the Support Bar to the Angle Adjustment Plate on the Strongback. Bolt it to the hole farthest away from the pivot bolt in the Strongback.
2. Attach the free end of the Support-Bar to the Support-Bar Pivot Tab on the Mounting Sleeve.
3. Place the Strongback/Mounting Sleeve Assembly on the mounting pole, aim it south and lock it in place by tightening the four set bolts on the sleeve using a 3/4" wrench.

This rack has six elevation angle set points: 15, 25, 35, 45, 55 and 65 degrees. For assembly and module mounting it is probably easiest to lock the rack in the flattest (15°) position (the hole in the Angle Adjustment Plate furthest from the Pivot Bolt).

4. Bolt the Cross-Bars to the Cross-Bar Mounting Angles welded to the top of the Strongback (see drawings) using the 3/8" x 3" bolts and hardware.
DO NOT FULLY TIGHTEN YET.

NOTE:

The Cross-Bars mount to the outside of the Cross-Bar Mounting Angles and are not "nested" inside the angle. Refer to drawing.

5. Bolt the Module Rails to the Module Rail Mounting Tab welded on the Cross-Bars (see drawings) using the 3/8" x 1" bolts and hardware. The inner Module Rails point toward the center of the rack and the outer rails point out as shown in the drawings.
DO NOT FULLY TIGHTEN YET.
6. Attach your photovoltaic modules to the module rails as shown in the drawings using the 1/4" stainless steel hardware provided. The holes in the Module Rails are over-sized -- be sure to use a flat washer against the rail.
7. Tighten all Cross-Bar, Module Rail, and solar module hardware.
8. When changing the elevation setting, loosen the pivot bolt before adjusting the rack. After changing the position of the Support-Bar tightening the two 3/8" bolts and make sure to tighten the pivot bolt.

POWER-FAB PV HARDWARE
Direct Power and Water Corp.
4000-B Vassar Drive NE
Albuquerque, NM 87107
800-260-3792, fax 505-889-3548
info@power-fab.com

SERIES 120-6 TOP-OF-POLE MOUNT

- MANUFACTURERS RECOMMENDATIONS -

SIDE VIEW

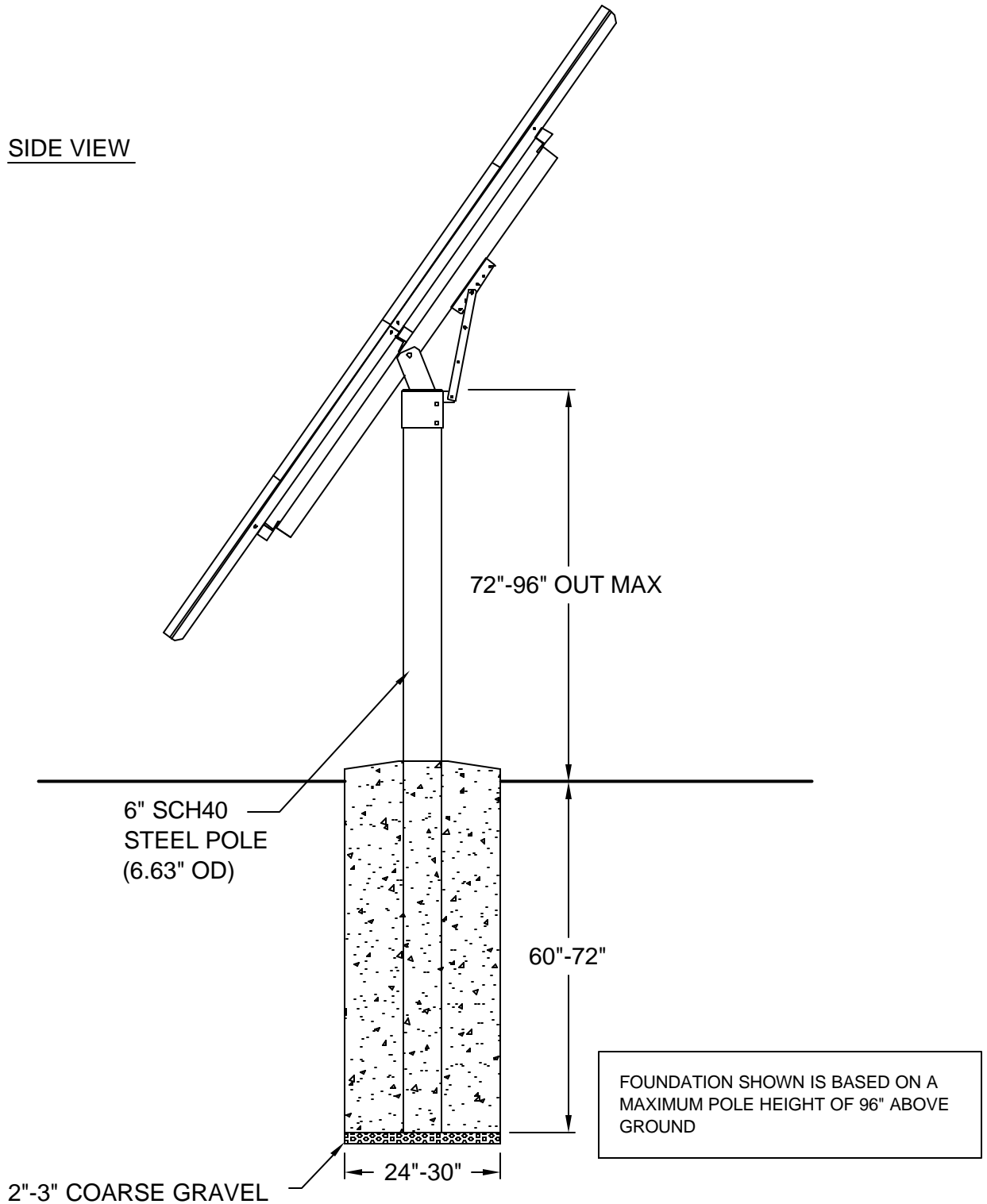

FOUNDATION RECOMMENDATIONS PER THE UNIFORM BUILDING CODE AND BASED ON THE FOLLOWING ASSUMPTIONS:

- EXPOSURE C (FLAT, OPEN TERRAIN)
- 2,000 PSI CONCRETE AT 28 DAYS (MINIMUM)
- 6" SCH40 STEEL PIPE
- 90 MPH MAXIMUM WIND SPEEDS
- SOIL TYPE 3-SANDY GRAVEL AND/OR GRAVEL

SEE INSTALLATION INSTRUCTIONS FOR SERIES 120-6 RACKS

DIRECT POWER & WATER CORPORATION

TITLE: SERIES 120-6 TOP-OF-POLE MOUNT FOUNDATION DETAIL		
FOR:	DRAWN BY: NR	ENGINEER: JR
	DATE: 11-26-02	DWG. NO.

THIS DRAWING IS THE PROPERTY OF DIRECT POWER & WATER CORPORATION AND CANNOT BE USED, COPIED, OR DISCLOSED WITHOUT PERMISSION

SERIES 120-6

SIDE VIEW

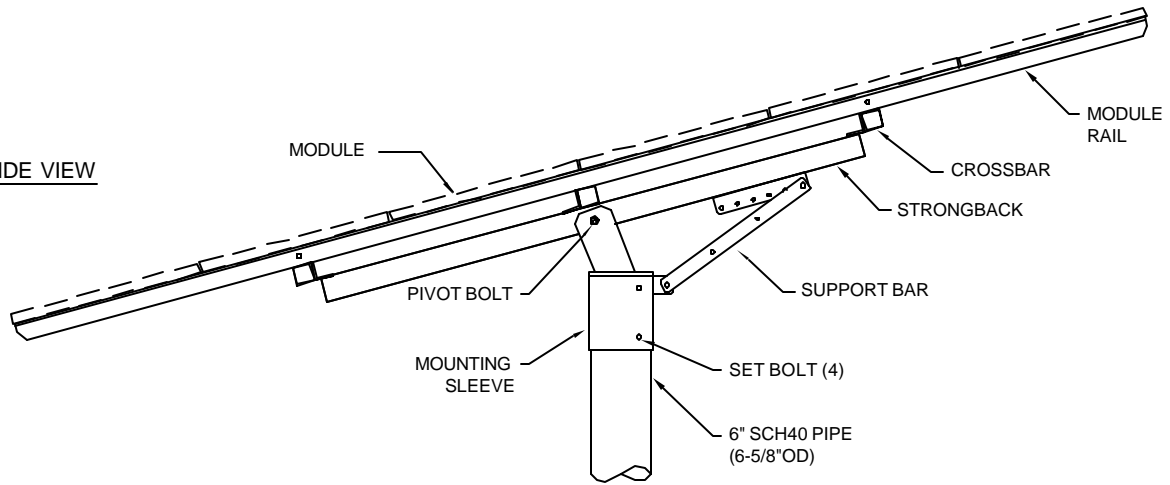

TOP VIEW

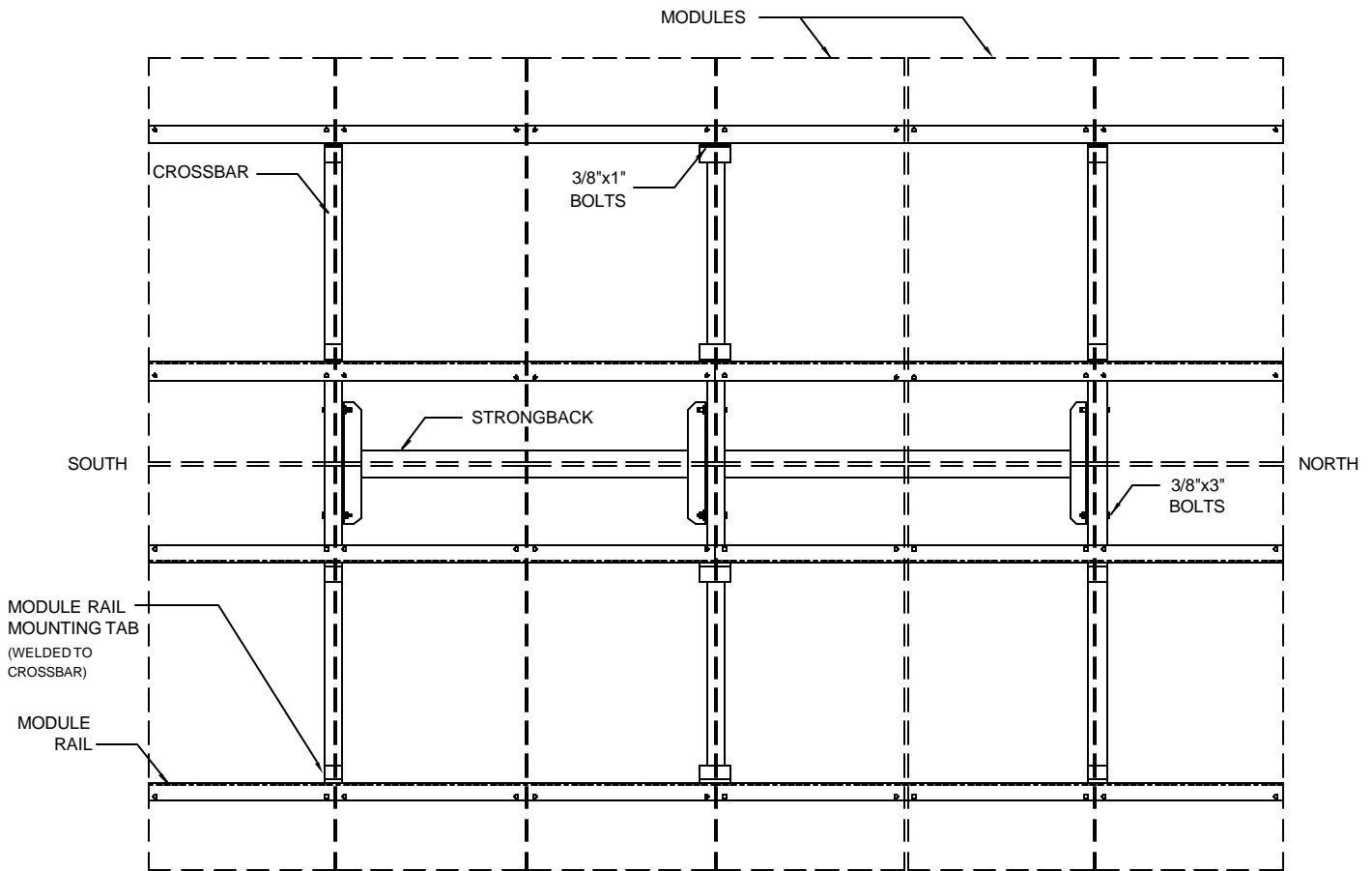

END VIEW

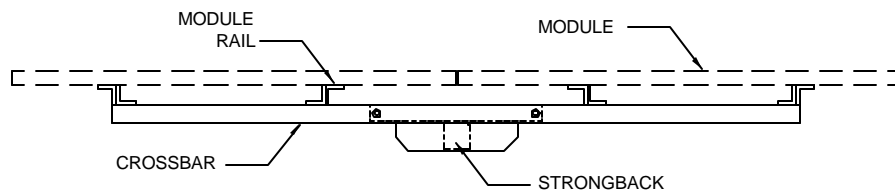

SERIES 120-6 TOP-OF-POLE MOUNTS

STRONGBACK/MOUNTING SLEEVE DETAIL

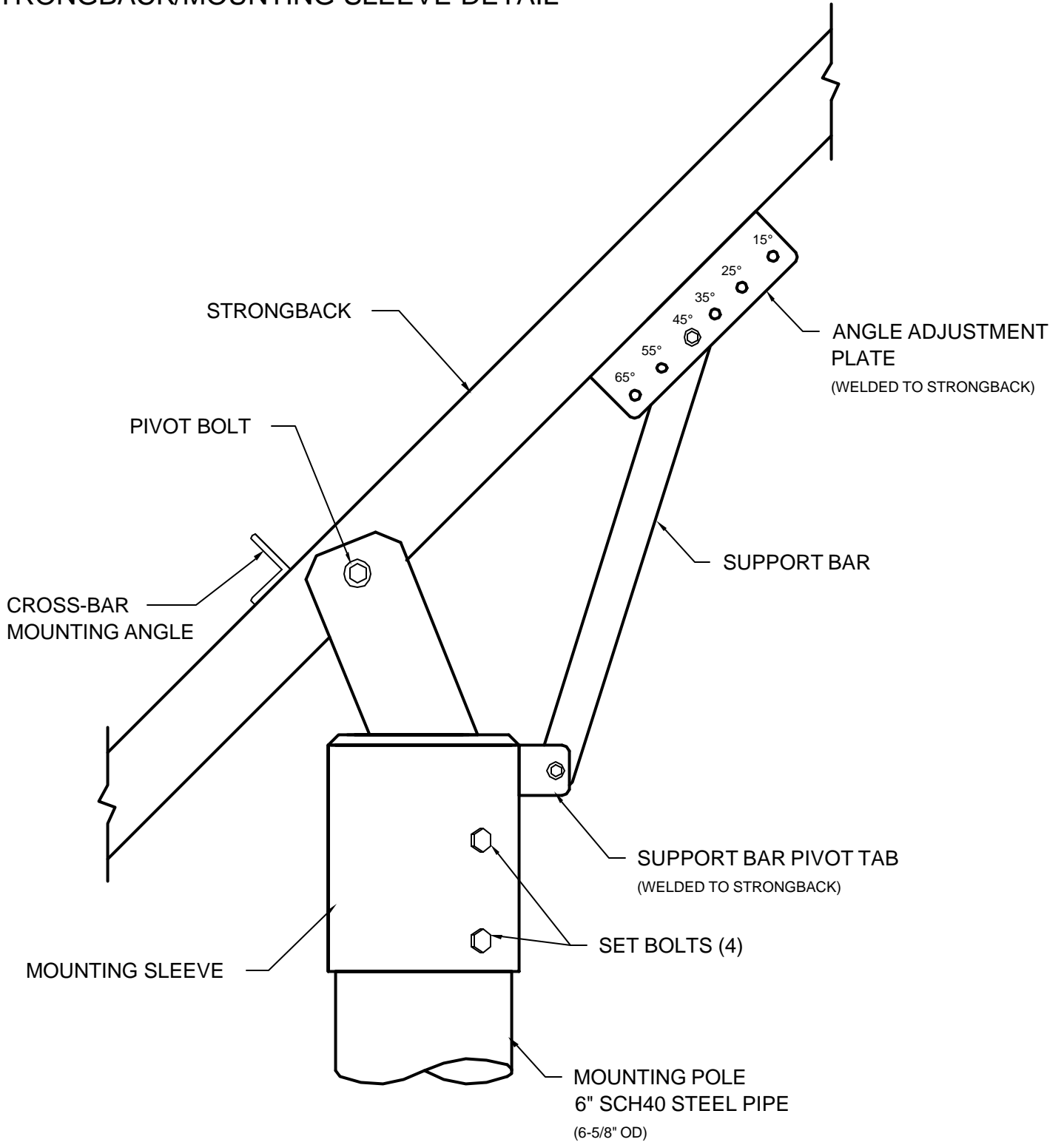

The following table provides “rule-of-thumb” guidelines for an average installation. Soil type varies widely from one region to another. The actual depth and diameter of the hole and the amount of concrete used is very dependent on soil type. Installations in loose, sandy soil will require a larger, deeper hole with more concrete than an installation in hard, rocky soil. The amount of pole sticking out of the ground and the wind speeds in your area also play an important role in determining the depth and diameter of the hole. If in doubt, we recommend that you consult a civil engineer in your area that is familiar with local soil conditions.

MODULE AREA	POLE SIZE (STEEL PIPE)	LENGTH IN GROUND	HEIGHT * ABOVE GROUND	HOLE DIAMETER
15 SQ. FT.	2" SCH40 (2-3/8" OD)	30"-36"	48"-72"	8"-12"
20 SQ. FT.	2.5" SCH40 (2-7/8" OD)	34"-40"	48"-72"	10"-14"
28 SQ. FT.	3" SCH40 (3-1/2" OD)	36"-42"	48"-72"	12"-16"
35 SQ. FT.	3" SCH40 (3-1/2" OD)	38"-44"	60"-72"	12"-16"
60 SQ. FT.	4" SCH40 (4-1/2" OD)	42"-48"	60"-72"	16"-24"
90 SQ. FT.	6" SCH40 (6-5/8" OD)	48"-60"	60"-84"	24"-30"
120 SQ. FT.	6" SCH40 (6-5/8" OD)	48"-72"	72"-84"	24"-30"
160 SQ. FT.	8" SCH40 (8-5/8" OD)	60"-78"	84"-102"	30"-36"
180 SQ. FT.	8" SCH40 (8-5/8" OD)	60"-78"	84"-102"	30"-36"
225 SQ. FT.	8" SCH80 (8-5/8" OD)	72"-84"	96"-120"	36"
260 SQ. FT.	8" SCH80 (8-5/8" OD)	72"-84"	96"-120"	36"

* If you need a taller pole for snow clearance or to clear nearby obstructions you will need to have more pole in the ground. For each extra foot that you add above ground you will need approximately 6" in the ground in concrete.

If you have to go more than 2ft-3ft higher than what is shown in the table you may need a larger diameter pole. Please consult the factory.

General Procedure: When your hole is ready place the piece of pipe in it so that it is resting on the bottom of the hole - it is a good idea to fill the bottom 2"-4" of the hole with rocks. Brace the pole plumb and pour concrete around it. Fill the hole to ground level, add a little extra concrete and use a trowel to form a mound around the pole so that the concrete slopes down away from the pole. Allow the concrete to set up for at least 24 hours before installing your rack.

DIRECT POWER AND WATER CORPORATION

4000-B Vassar Drive NE

Albuquerque, NM 87107

Ph: 800-260-3792 Fax: 505-889-3548

POWER-FAB PV HARDWARE
DIRECT POWER AND WATER CORPORATION LIMITED WARRANTY

Direct Power & Water Corporation (DP&WC) warrants to the original customer that its products shall be free from defects in materials and workmanship for a period of five (5) years.

At its option, DP&WC will repair or replace at no charge any DP&WC product that proves to be defective within such warranty period. This warranty shall not apply if the DP&WC product has been damaged by unreasonable use, accident, negligence, service or modification by anyone other than Direct Power & Water Corporation, or by any other causes unrelated to materials and workmanship.

The original consumer purchaser must retain original purchase receipt for proof of purchase as a condition precedent to warranty coverage. To receive in-warranty service, the defective product must be received no later than one (1) week after the end of the warranty period. The product must be accompanied by proof of purchase and Return Authorization (RA) number issued by DP&WC. For an RA number contact Direct Power & Water Corporation, 4000-B Vassar Dr NE, Albuquerque, New Mexico 87107 (505) 889-3585. Purchasers must prepay all delivery costs or shipping charges to return any defective DP&WC product under this warranty policy.

Except for the warranty that the products are made in accordance with the specifications therefore supplied or agreed to by customer, DP&WC MAKES NO WARRANTY EXPRESSED OR IMPLIED, AND ANY IMPLIED WARRANTY OF MERCHANTABILITY OR FITNESS FOR A PARTICULAR PURPOSE WHICH EXCEEDS THE FOREGOING WARRANTY IS HEREBY DISCLAIMED BY DP&WC AND EXCLUDED FROM ANY AGREEMENT MADE BY ACCEPTANCE OF ANY ORDER PURSUANT TO THIS QUOTATION. DP&WC WILL NOT BE LIABLE FOR ANY CONSEQUENTIAL DAMAGES, LOSS OR EXPENSE ARISING IN CONNECTION WITH THE USE OF OR THE INABILITY TO USE ITS GOODS FOR ANY PURPOSE WHATSOEVER. DP&WC'S MAXIMUM LIABILITY SHALL NOT IN ANY CASE EXCEED THE CONTRACT PRICE FOR THE GOODS CLAIMED TO BE DEFECTIVE OR UNSUITABLE.

Products will be considered accepted by customer unless written notice to the contrary is given to DP&WC within ten (10) days of such delivery to customer. DP&WC shall not in any case be liable for any event occurring or defect discovered with regard to said product unless written notice thereof is given to DP&WC within ninety (90) days of such product delivery to customer.

DP&WC is not responsible for loss or damage to products owned by customer and located on DP&WC's premises caused by fire or other casualties beyond DP&WC's control. This warranty is in lieu of all other warranties expressed or implied.

POWER-FAB PV HARDWARE
DIRECT POWER AND WATER CORPORATION
4000-B Vassar Drive NE, Albuquerque, NM 87107
Ph: 505-889-3585 Fax: 505-889-3548
Email: info@power-fab.com