

The RoofTrac® Tilt Up Kit is an easy-to-install accessory for your RoofTrac® system.

When integrating with the FastJack® attachment device, the installer **MUST** use strut to grid the system. Please refer to installation guide for detailed installation instructions.

SPECIFICATIONS

- Materials:** Anodized Aluminum & stainless steel hardware
- Engineering:** 50 lbs. per ft² (selected modules only)
125 mph approx. wind load
- Product**
- Integration:** RoofTrac® 1.5" Support Rail
- Order #s:** A-TU24-3

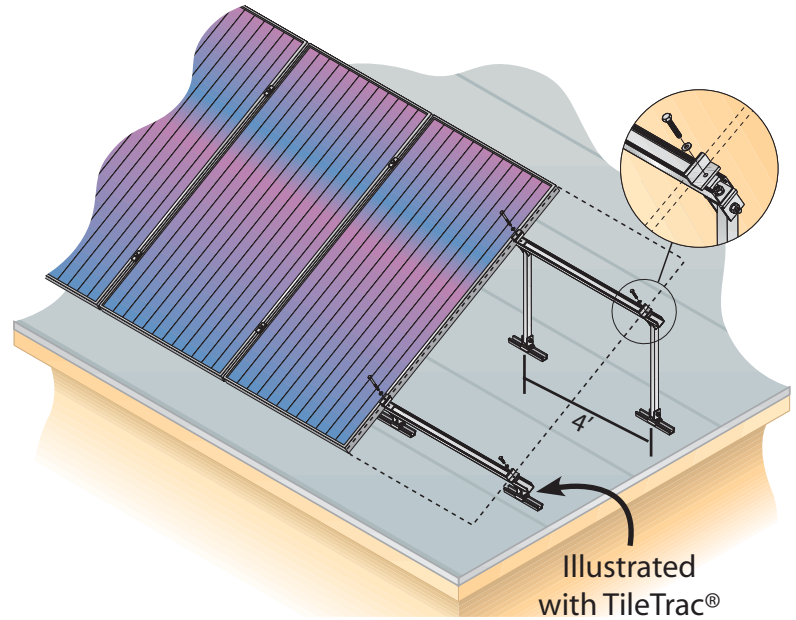

INCLUDED PARTS (Per Kit)

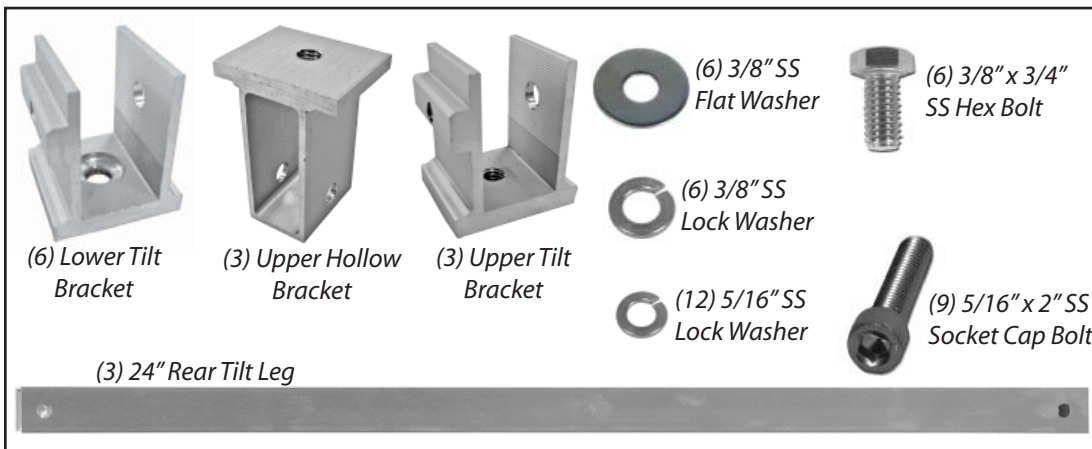

Per Box (3 Kits per box):

- (18) Lower Tilt Brackets
- (9) Upper Hollow Brackets
- (9) Upper Tilt Bracket
- (9) 24" Rear Tilt Leg
- (18) 3/8" SS Flat Washer
- (18) 3/8" SS Lock Washer
- (36) 5/16" SS Lock Washer
- (18) 3/8" x 3/4" SS Hex Bolt
- (27) 5/16" x 2" SS Socket Cap Bolt

Requires 1/4" Socket Drive for Installation

MODULES SUPPORTED BY THE TILT-UP KIT:

BP Solar
GE Energy
Kyocera
Shell Solar
Sharp
SunPower



(800) 967-6917
www.dcpower-systems.com

Proper Orientation/Layout

