



Sunny Boy Accessories
SMA POWER BALANCER
Installation Guide



Copyright © 2010 SMA America, LLC. All rights reserved.

No part of this document may be reproduced, stored in a retrieval system, or transmitted, in any form or by any means, electronic, mechanical, photographic, magnetic or otherwise, without the prior written permission of SMA America, LLC.

SMA America, LLC makes no representations, express or implied, with respect to this documentation or any of the equipment and/or software it may describe, including (with no limitation) any implied warranties of utility, merchantability, or fitness for any particular purpose. All such warranties are expressly disclaimed. Neither SMA America, LLC nor its distributors or dealers shall be liable for any indirect, incidental, or consequential damages under any circumstances.

(The exclusion of implied warranties may not apply in all cases under some statutes, and thus the above exclusion may not apply.)

Specifications are subject to change without notice. Every attempt has been made to make this document complete, accurate and up-to-date. Readers are cautioned, however, that SMA America, LLC reserves the right to make changes without notice and shall not be responsible for any damages, including indirect, incidental or consequential damages, caused by reliance on the material presented, including, but not limited to, omissions, typographical errors, arithmetical errors or listing errors in the content material.

All trademarks are recognized even if these are not marked separately. Missing designations do not mean that a product or brand is not a registered trademark.

The *Bluetooth*[®] word mark and logos are registered trademarks owned by Bluetooth SIG, Inc. and any use of such marks by SMA America, LLC is under license.

SMA America, LLC
3801 N. Havana Street
Denver, CO 80239 U.S.A.

IMPORTANT SAFETY INSTRUCTIONS

SAVE THESE INSTRUCTIONS

This manual contains important instructions for SMA Power Balancer accessory, that must be followed during installation and maintenance of the accessory.

The SMA Power Balancer is designed and tested according to international safety requirements, but as with all electrical and electronic equipment, certain precautions must be observed when installing and/or operating the SMA Power Balancer. To reduce the risk of personal injury and to ensure the safe installation and operation of the SMA Power Balancer, you must carefully read and follow all instructions, cautions and warnings in this installation guide.

Warnings in this document

A warning describes a hazard to equipment or personnel. It calls attention to a procedure or practice, which, if not correctly performed or adhered to, could result in damage to or destruction of part or all of the SMA equipment and/or other equipment connected to the SMA equipment or personal injury.



DANGER

DANGER indicates a hazardous situation which, if not avoided, will result in death or serious injury.



WARNING

WARNING indicates a hazardous situation which, if not avoided, could result in death or serious injury.



CAUTION

CAUTION indicates a hazardous situation which, if not avoided, could result in minor or moderate injury.

NOTICE

NOTICE is used to address practices not related to personal injury.

Other symbols in this document

In addition to the safety and hazard symbols described on the previous pages, the following symbol is also used in this installation guide:



Information

This symbol accompanies notes that call attention to supplementary information that you must know and use to ensure optimal operation of the system.

General Warnings



General Warnings

All electrical installations must be done in accordance with all local electrical codes and the *National Electrical Code*®, ANSI/NFPA 70. For installation in Canada the installations must be done in accordance with applicable Canadian standards.

The SMA Power Balancer contains no user-serviceable parts. For all repair and maintenance, always return the unit to an authorized SMA Service Center.

Before installing or using the SMA Power Balancer, read all of the instructions, cautions, and warnings on the SMA Power Balancer in this installation guide.

Wiring of the SMA Power Balancer must be made by qualified personnel only.

Table of Contents

1	Notes on this manual	9
1.1	Validity	9
1.2	Target group	9
1.3	Nomenclature	9
2	Safety	10
2.1	Appropriate usage	10
2.2	Safety instructions	10
3	Scope of delivery	11
4	Grid feeding with the SMA Power Balancer	12
5	Configuration	14
5.1	Configuration options	14
5.1.1	Off	15
5.1.2	Power Guard	15
5.1.3	Phase Guard	16
5.1.4	Fault Guard	17
6	Wiring	18
6.1	Connecting SB 5000-US/SB 6000-US/SB 7000-US/SB 8000-US	18
6.2	Connecting SB 8000TL-US/SB 9000TL-US/SB 10000TL-US	21
7	Testing the function	25
8	Contact	26

1 Notes on this manual

1.1 Validity

This installation guide describes the assembly, installation, configuration and commissioning of the SMA Power Balancer. This manual does not cover any details concerning connected inverters and other equipment.

1.2 Target group

This manual is for qualified personnel. Qualified personnel have received training and have demonstrated skills and knowledge in the construction and operation of this device. Qualified personnel are trained to deal with the dangers and hazards involved in installing electric devices.

1.3 Nomenclature

In this document SMA America Production, LLC is referred to in the following as SMA.

The nomenclature specified here for menus and parameters applies throughout the entire manual.

2 Safety

2.1 Appropriate usage

The SMA Power Balancer can only be used in combination with the following types of inverter:

- Sunny Boy 5000-US
- Sunny Boy 6000-US
- Sunny Boy 7000-US
- Sunny Boy 8000-US

- Sunny Boy 8000TL-US (SB 8000TLUS-10)
- Sunny Boy 9000TL-US (SB 9000TLUS-10)
- Sunny Boy 10000TL-US (SB10000TLUS-10)



The installation method will vary with the different types of inverters.

Read this installation guide carefully.

Also refer to the installation guide of the appropriate inverter.

Always use the SMA Power Balancer for linking 3 inverters. The unbalanced load between the 3 inverters must not be greater than the prescribed maximum unbalanced load of the utility grid.

Do not use the SMA Power Balancer in combination with other inverters and for other purposes than described in this manual.

2.2 Safety instructions

	DANGER
<p>High voltages are present in the inverter during operation.</p> <p>Death or serious injury due to electric shock.</p> <ul style="list-style-type: none">• All work on the inverter must only be carried out by qualified personnel.	

3 Scope of delivery

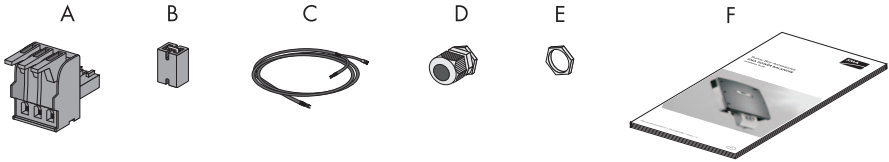

Position	Number	Description
A	3	Spring clamp male connector
B	1	Jumper
C	2	Power Balancer cable
D	4	Cable gland
E	4	Lock nut for cable gland
F	1	Installation guide

4 Grid feeding with the SMA Power Balancer

The SMA Power Balancer enables a circuit connection of 3 inverters to a three-phase grid-feed system.

Connection to a three-phase system, 208 V/240 V

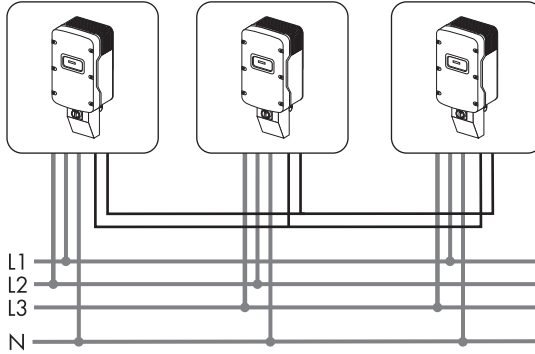

- One inverter connected to L1, L2 and N, if present.
- One inverter connected to L2, L3 and N, if present.
- One inverter connected to L1, L3 and N, if present.

Connection to a three-phase system, 277 V

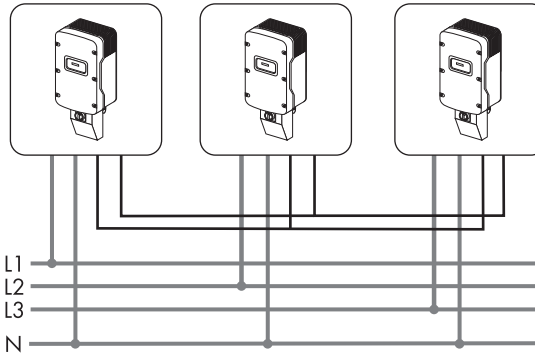

- One inverter connected to L1 and N.
- One inverter connected to L2 and N.
- One inverter connected to L3 and N.

Adjusting reaction to device fault and grid fault

By activating this Power Balancer feature, you can stipulate how the other two inverters are to react if there is a device fault with the third inverter or there is a grid voltage fault.



Three-phase grid connection

For further information on three-phase grid connection refer to the download area at www.SMA-America.com.

The connections for the SMA Power Balancer are galvanically isolated from the rest of the inverter circuit.

5 Configuration

The SMA Power Balancer is deactivated at the factory using the parameter "PowerBalancer" (parameter setting = off).



The SMA Power Balancer can only be activated and configured using a communication device.

- Ensure that a communication device is installed in the Sunny Boy inverters you want operate with the SMA Power Balancer.

5.1 Configuration options

There are 4 different configuration options for the "PowerBalancer" parameter.

- Off
- Power Guard
- Phase Guard
- Fault Guard



Local connection requirements

Select the respective setting and always observe the local connection requirements and provisions of your utility operator.

5.1.1 Off

The SMA Power Balancer is deactivated at the factory.

- In the event of a **grid voltage fault** or **device fault** of an inverter, only the affected inverter disconnects from the grid. The other two inverters continue to run at an undiminished power level.

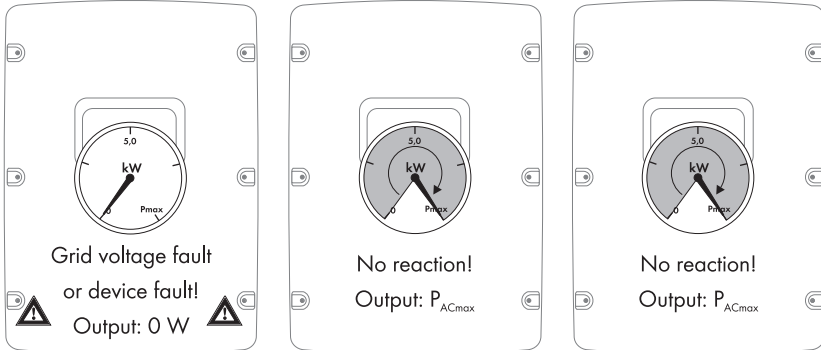

5.1.2 Power Guard

Select this setting if, in the event of a failure, the unbalanced load should be limited to a defined value over a 10-minute average.

If one of the three inverters indicates a **grid voltage fault** or **device fault** and stops feeding in, the other two inverters automatically limit their power to a defined value over a 10 minute average.

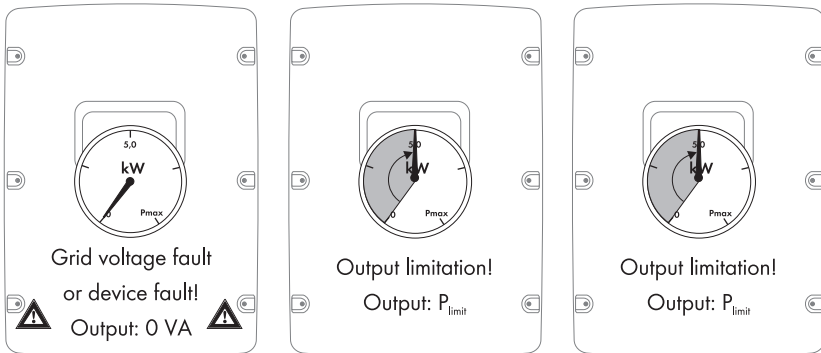

5.1.3 Phase Guard

This operating mode enables the implementation of three-phase grid voltage monitoring.

- If one of the 3 inverters indicates a **grid voltage fault** and stops feeding in, the other two inverters also disconnect from the grid automatically.

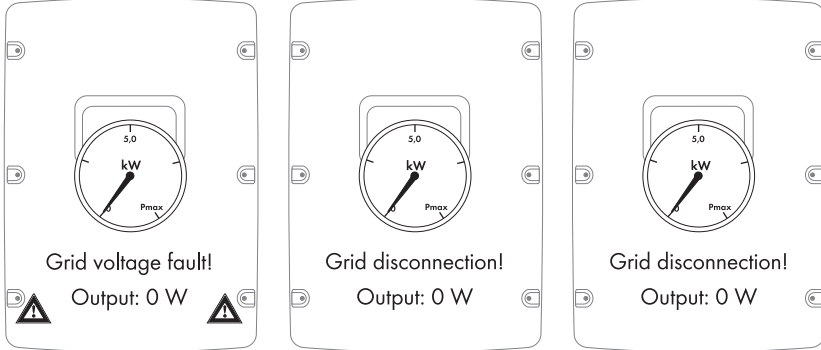

- If one of the 3 inverters indicates a **device fault** and stops feeding in, the other two inverters are not affected and continue to feed in at full power.

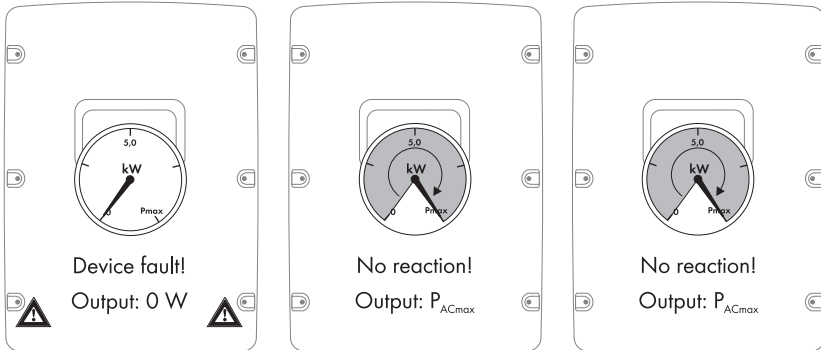

5.1.4 Fault Guard

This operating mode enables the implementation of three-phase grid voltage monitoring that also reacts to device failures.

- If one of the 3 inverters indicates a **grid voltage fault** and stops feeding in, the other two inverters also disconnect from the grid immediately.

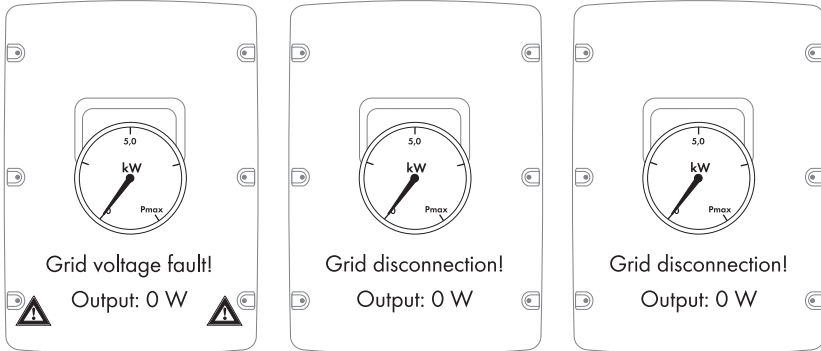

- If one of the 3 inverters indicates a **device fault** and stops feeding in, the other two inverters also disconnect from the grid with a delay of 5 minutes.

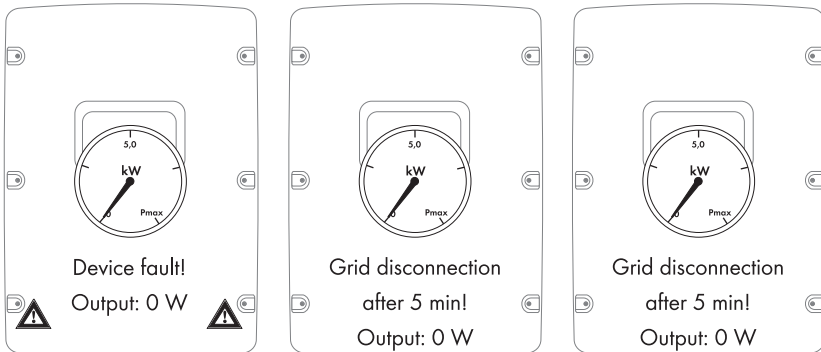

6 Wiring

6.1 Connecting SB 5000-US/SB 6000-US/SB 7000-US/SB 8000-US

Installation overview

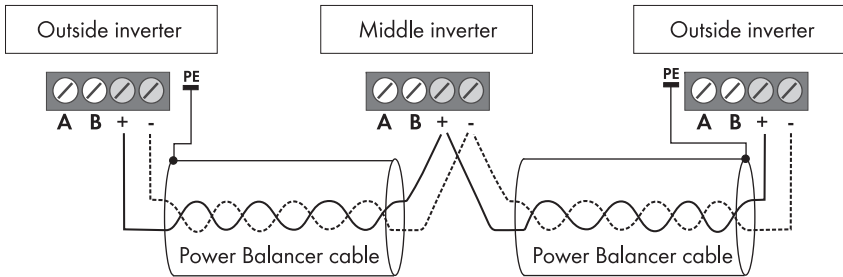

i If the provided Power Balancer cable is too short, it can be extended.

- The maximum length must not exceed 928 ft. (300 m).

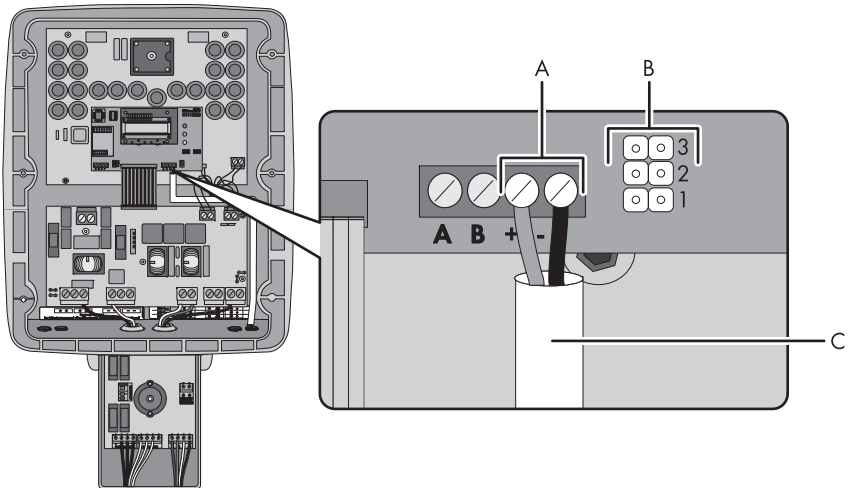

Object	Description
A	Screw terminal block
B	Jumper slot
C	Power Balancer cable

1. Open the 2 outside inverters as described in the Sunny Boy installation guide.
2. Remove 1 filler plug on the bottom right of the 2 outside inverters.
3. Insert cable glands into each opening and fasten each with a lock nut.

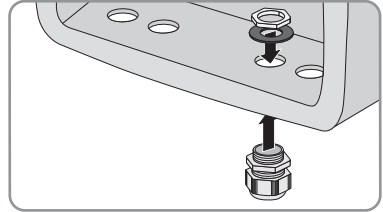

4. Unscrew the cap nut of the installed cable glands a bit.
5. Thread a Power Balancer cable(C) through the cable glands into the 2 outside inverters.



Only use the cable end with the separate shield flat connector.

6. Draw each Power Balancer cable up to the screw terminal block (A).
7. Tighten the cap nut of each cable gland in order to secure the Power Balancer cable.
8. Connect the conductors of the Power Balancer cable (C) to the screw terminal block (A).
 - Red conductor to terminal +.
 - Blue conductor to terminal -.

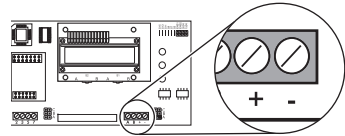

Linking the 3 inverters at the middle inverter

9. Open the middle inverter as described in the Sunny Boy installation guide.
10. Remove 2 filler plugs on the bottom right of the middle inverter.
11. Insert cable glands into each opening and fasten each with a lock nut.

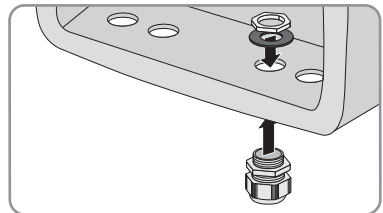

12. Unscrew the cap nut of the installed cable glands a bit.
13. Thread the Power Balancer cables from the 2 outside inverters through the cable glands into the middle inverter.
Only use 1 cable gland per cable.
14. Draw both Power Balancer cables up to the screw terminal block (A).

15. Connect the conductors of both Power Balancer cables to the screw terminal block.
 - Both red conductors to terminal +.
 - Both blue conductors to terminal -.
16. Install the jumper to the middle inverter on position (1) of the jumper slot (B).

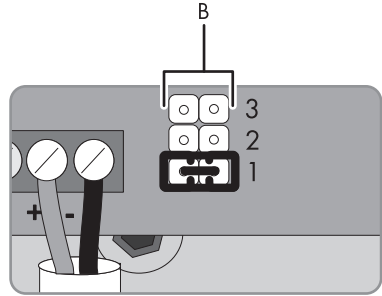

Connecting the shield wire at the 2 outside inverters

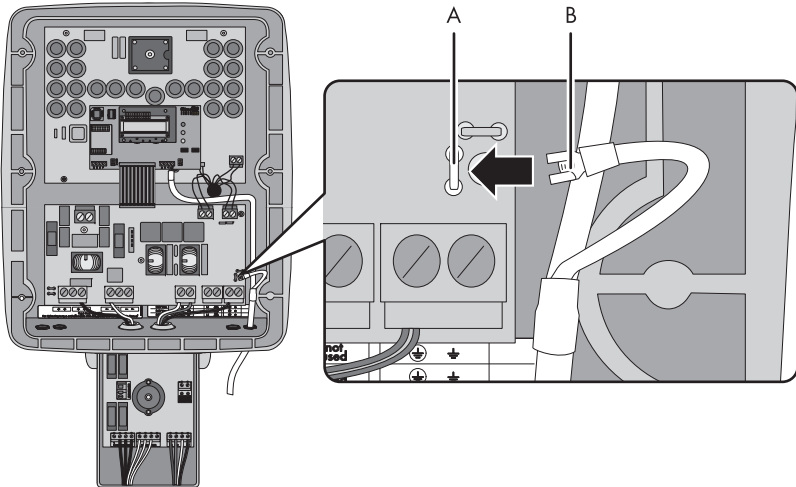

Position	Description
A	Grounding flat pin
B	Shield flat connector

17. Connect the shield flat connector (B) of the Power Balancer cable to the grounding flat pin (A).

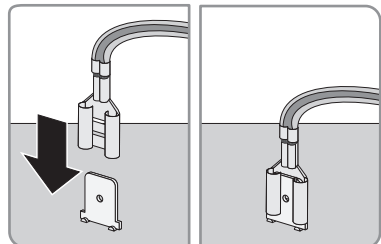

18. Close all 3 inverters as described in the Sunny Boy installation guide.

6.2 Connecting SB 8000TL-US/SB 9000TL-US/SB 10000TL-US

Installation overview

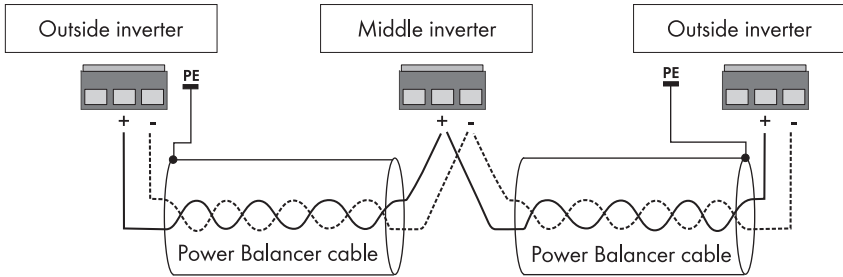

If the provided Power Balancer cable is too short, it can be extended.

- The maximum length must not exceed 928 ft. (300 m).

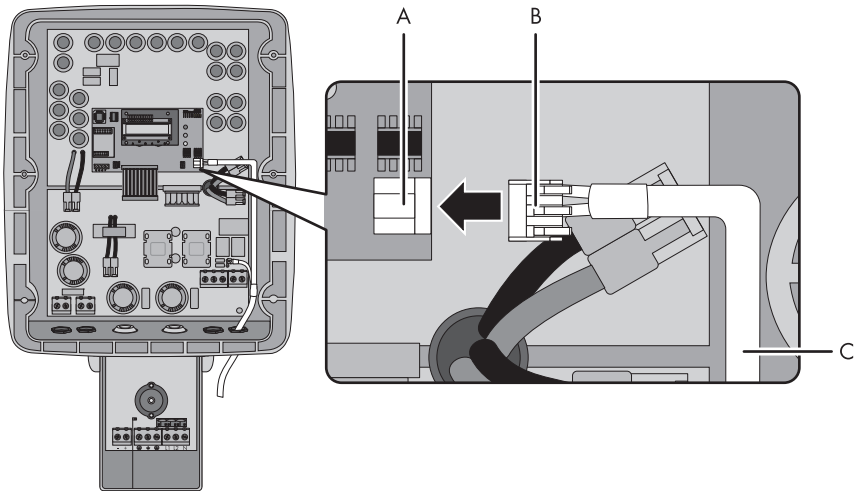

Position	Description
A	Three-pole terminal block
B	Spring clamp male connector
C	Power Balancer cable

1. Open the 2 outside inverters as described in the Sunny Boy installation guide.
2. Remove 1 filler plug on the bottom right of the 2 outside inverters.
3. Insert cable glands into each opening and fasten each with a lock nut.

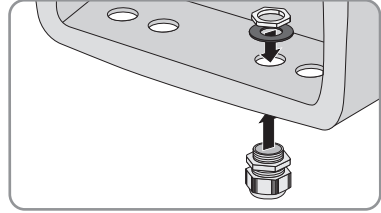

4. Unscrew the cap nut of the installed cable glands a bit.
5. Thread a Power Balancer cable (C) through the cable glands into the 2 outside inverters.



Only use the cable end with the separate shield flat connector.

6. Draw each cable up to the three-pole terminal block (A).
7. Tighten the cap nut of each cable gland in order to secure the Power Balancer cable.
8. Insert the conductors of the Power Balancer cable into the spring clamp male connector.
 - Red conductor into the middle terminal.
 - Blue conductor into the right terminal.
 - The left terminal remains unused.

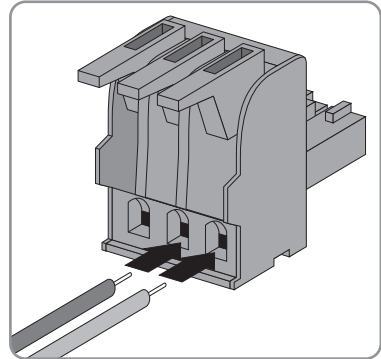

9. Close all clamp terminals by pushing down the levers.

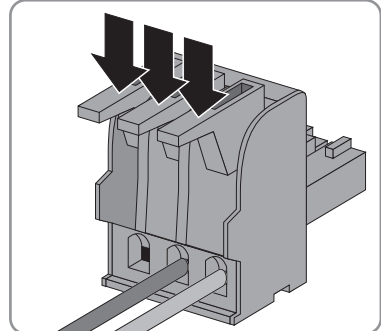

10. Plug the spring clamp male connector (B) to the three-pole terminal block (A).

Linking the 3 inverters at the middle inverter

11. Open the middle inverter as described in the Sunny Boy installation guide.
12. Remove 2 filler plugs on the bottom right of the middle inverter.
13. Insert cable glands into each opening and fasten each with a lock nut.

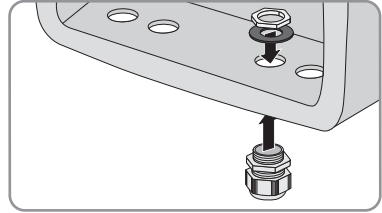

14. Unscrew the cap nut of the installed cable glands a bit.
15. Thread the Power Balancer cables from the 2 outside inverters through the cable glands into the middle inverter.
Only use 1 cable gland per cable.
16. Draw each cable up to the three-pole terminal block (A).
17. Tighten the cap nut of each cable gland in order to secure the Power Balancer cable.

18. Insert the conductors of both Power Balancer cables into 1 spring clamp male connector.
 - Both red conductors into the middle terminal.
 - Both blue conductors into the right terminal.
 - The left terminal remains unused.

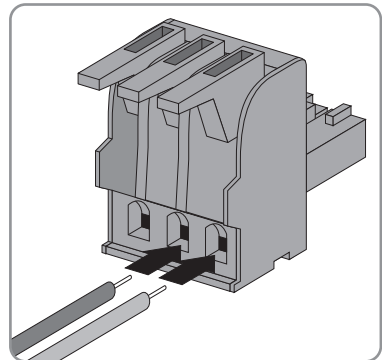

19. Close all clamp terminals by pushing down the levers.

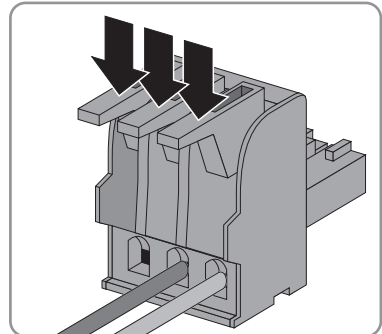

20. Plug the spring clamp male connector (B) to the three-pole terminal block (A).
21. Install the jumper to the middle inverter on position (1) of the jumper slot.

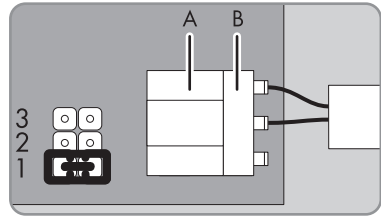

Connecting the shield wire at the 2 outside inverters

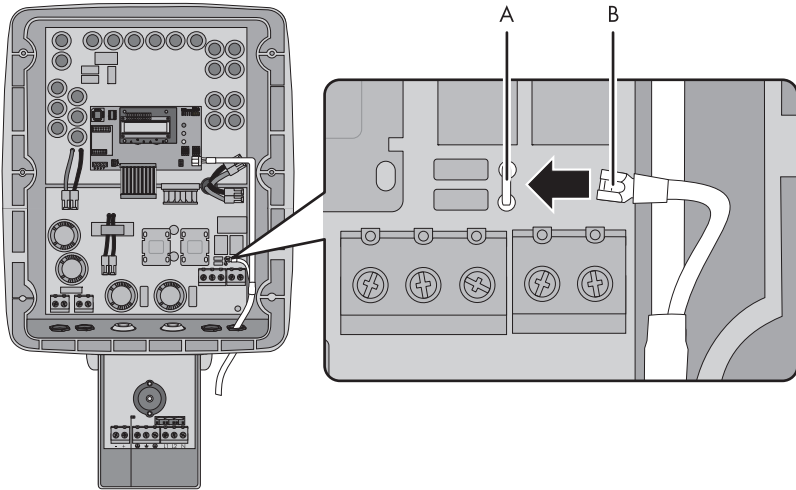

Position	Description
A	Grounding flat pin
B	Shield flat connector

22. Connect the shield flat connector (B) of the Power Balancer cable to the grounding flat pin (A).

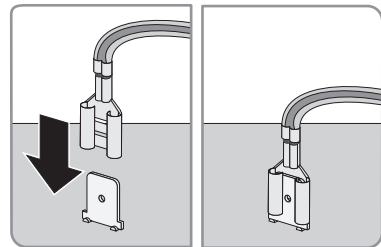

23. Close all 3 inverters as described in the Sunny Boy installation guide.

7 Testing the function

Check if the SMA Power Balancer operates correctly:

1. Select the "PhaseGuard" setting of the "PowerBalancer" parameter for all three inverters.
2. Check whether all inverters in the group are feeding the grid normally.

If the green LED lights up steadily or if the following display message appears, proceed with point 3.

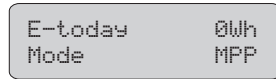

or

If all inverters in this group show the adjacent display message: Check the installation of the SMA Power Balancer and contact the SMA Serviceline if necessary.

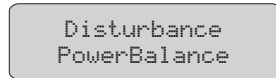

3. Switch off the line circuit breaker for one of the three inverters.

The inverter with a deactivated line circuit breaker indicates a grid voltage showing following display message ("Bfr" and "Srr" are irrelevant).

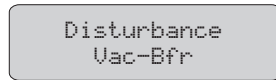

The remaining inverters then also disconnect from the grid showing following display message.

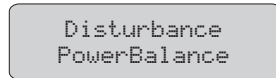

Both inverters subsequently switch to "Balanced" mode.

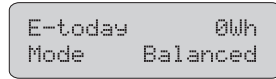

- If the inverters react as described above, the functionality test has been completed successfully. Otherwise, check the configuration.
4. If applicable, reset the "PowerBalancer" parameter to the desired setting in all inverters.
5. Switch on the line circuit breaker again.
6. The functionality test has been completed.

8 Contact

If you have technical problems concerning our products, contact your installer or the SMA Serviceline. We require the following information in order to provide you with the necessary assistance:

- Inverter type
- Type and number of modules connected
- Communication method
- Serial number of the Sunny Boy
- Failure or warning number of the Sunny Boy
- Display of the Sunny Boy

SMA Solar Technology America, LLC

6020 West Oaks Blvd

Rocklin, CA 95765

Tel. +1 916 625 0870

Tel. +1 877-MY SMA TECH

Tel. +1 877 697 6283 (Toll free, available for USA, Canada and Puerto Rico)

Fax +1 916 625 0871

Service@SMA-America.com

www.SMA-America.com

SMA America, LLC

www.SMA-America.com

