

Xantrex™ TR Series Inverter/Charger

Xantrex TR1512 120 60

Xantrex TR1524 120 60

Xantrex TR2412 120 60

Xantrex TR2424 120 60

Xantrex TR3624 120 60

Xantrex TR1512 230 50

Xantrex TR1524 230 50

Xantrex TR2424 230 50

Operation Manual

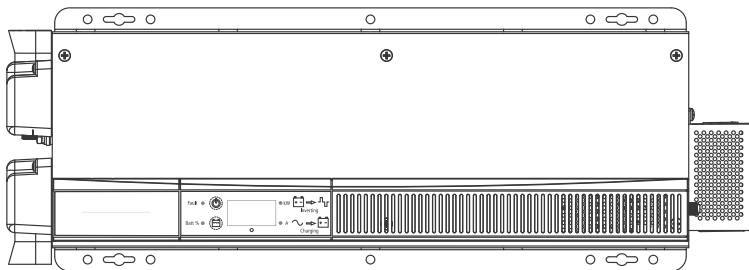

Xantrex TR Series Inverter/Charger

Operation Manual

Trademarks

Schneider Electric, the **Schneider Electric logo**, and **Xantrex** are trademarks or registered trademarks of the Schneider Electric group of companies. Other trademarks, registered trademarks, and product names are the property of their respective owners and are used herein for identification purposes only.

Notice of Copyright

Copyright © 2008, 2009, 2010 Xantrex Technology Inc. All rights reserved. No part of this document may be reproduced in any form or disclosed to third parties without the express written consent of:

Xantrex Technology Inc.
161-G South Vasco Road
Livermore, California USA 94551

Xantrex Technology Inc. reserves the right to revise this document and to periodically make changes to the content hereof without obligation or organization of such revisions or changes unless required to do so by prior arrangement.

Exclusion for Documentation

UNLESS SPECIFICALLY AGREED TO IN WRITING, XANTREX TECHNOLOGY INC. ("XANTREX")

(A) MAKES NO WARRANTY AS TO THE ACCURACY, SUFFICIENCY OR SUITABILITY OF ANY TECHNICAL OR OTHER INFORMATION PROVIDED IN ITS MANUALS OR OTHER DOCUMENTATION;

(B) ASSUMES NO RESPONSIBILITY OR LIABILITY FOR LOSSES, DAMAGES, COSTS OR EXPENSES, WHETHER SPECIAL, DIRECT, INDIRECT, CONSEQUENTIAL OR INCIDENTAL, WHICH MIGHT ARISE OUT OF THE USE OF SUCH INFORMATION. THE USE OF ANY SUCH INFORMATION WILL BE ENTIRELY AT THE USER'S RISK; AND

(C) REMINDS YOU THAT IF THIS MANUAL IS IN ANY LANGUAGE OTHER THAN ENGLISH, ALTHOUGH STEPS HAVE BEEN TAKEN TO MAINTAIN THE ACCURACY OF THE TRANSLATION, THE ACCURACY CANNOT BE GUARANTEED. APPROVED XANTREX CONTENT IS CONTAINED WITH THE ENGLISH LANGUAGE VERSION WHICH IS POSTED AT WWW.SCHNEIDER-ELECTRIC.COM.

Date and Revision

March 2010 Revision C

Part Number





975-0391-01-01

Product Number

Xantrex TR1512 120 60, Xantrex TR2412 120 60, Xantrex TR1524 120 60, Xantrex TR2424 120 60, Xantrex TR3624 120 60, Xantrex TR1512 230 50, Xantrex TR1524 230 50, Xantrex TR2424 230 50

Contact Information

www.schneider-electric.com

			
North America	1 650 351 8237 1 866 519 1470	1 925 245 1022	re.techsupport@schneider-electric.com
La France	+0825012999		fr-re-techsupport@fr.schneider-electric.com
Deutschland	+49 (0) 180 575 6575	+49 (0) 2102 404 7101	solarservice@de.schneider-electric.com
España	+34 93 498 7466	+34 93 305 5026	re.techsupport@es.schneider-electric.com
L'Italia	+39 035 4151111	+39 035415 3200	IT-pronto-contatto@it.schneider-electric.com

For other country details please contact your local Schneider Electric Sales Representative or visit our website at: <http://www.schneider-electric.com/sites/corporate/en/support/operations/local-operations/local-operations.page>

About This Manual

Purpose

The purpose of this Operation Manual is to provide explanations and procedures for operating and troubleshooting the Schneider Electric Xantrex TR Series Inverter/Charger.

Scope

The Manual provides safety guidelines, and procedures for operating and troubleshooting the inverter. It does not provide details about particular brands of batteries. You need to consult individual battery manufacturers for this information.

Audience

The Manual is intended for anyone who needs to operate or troubleshoot the Xantrex TR Series Inverter/Charger. Installers must be certified technicians or electricians.

Organization

This Manual is organized into three chapters and one appendix.

Chapter 1, "Introduction" contains information about the features and functions of the Xantrex TR Series Inverter/Charger.

Chapter 2, "Operation" contains information about how to operate the Xantrex TR Series Inverter/Charger.

Chapter 3, "Troubleshooting" contains information about how to troubleshoot possible error conditions while using the Xantrex TR Series Inverter/Charger.

Appendix A, "Specifications" contains information about the electrical, environmental and regulatory specifications of the Xantrex TR Series Inverter/Charger.

Conventions Used

The following conventions are used in this guide.



WARNING

Warnings identify conditions or practices that could result in personal injury or loss of life



CAUTION

Cautions identify conditions or practices that could result in damage to the unit or other equipment.

Important: These notes describe things which are important for you to know, but not as serious as a caution or warning.

Model Numbering

This Manual contains information for eight models of the Xantrex TR Series Inverter/Charger.

Within this Manual, if information applies to all models of the Xantrex TR Series Inverter/Charger then they will be referred to as the Xantrex TR Series. If information only applies to select models then the model number will be referenced as shown in the table below. Make sure you know which model Xantrex TR Series Inverter/Charger you have purchased.

Model Number	Input Voltage	Power	Battery Bank Size	Frequency
Xantrex TR1512 120 60	120 Vac	1500 VA	12 Volt	60 Hz
Xantrex TR2412 120 60	120 Vac	2400 VA	12 Volt	60 Hz
Xantrex TR1524 120 60	120 Vac	1500 VA	24 Volt	60 Hz
Xantrex TR2424 120 60	120 Vac	2400 VA	24 Volt	60 Hz
Xantrex TR3624 120 60	120 Vac	3600 VA	24 Volt	60 Hz
Xantrex TR1512 230 50	230 Vac	1500 VA	12 Volt	50 Hz
Xantrex TR1524 230 50	230 Vac	1500 VA	24 Volt	50 Hz
Xantrex TR2424 230 50	230 Vac	2400 VA	24 Volt	50 Hz

Abbreviations and Acronyms

AC	Alternating Current
ASC	Authorized Service Center
COM	Communications Port
DC	Direct Current
PV	Photovoltaic
RE	Renewable Energy
RMA	Return Material Authorization
Xantrex TR Series	Xantrex TR Series Inverter/Charger

Related Information

You can find more information about Schneider Electric as well as its products and services at www.schneider-electric.com.

IMPORTANT SAFETY INSTRUCTIONS

SAVE THESE INSTRUCTIONS

THIS MANUAL CONTAINS IMPORTANT INSTRUCTIONS THAT SHALL BE FOLLOWED DURING OPERATION OF ALL XANTREX TR SERIES INVERTER/CHARGER MODELS.



WARNING: Limitations on use

The Xantrex TR Series is not intended for use in connection with life support systems or other medical equipment or devices.

General

1. Before installing and using the Xantrex TR Series Inverter/Charger, read all instructions and cautionary markings on the Xantrex TR Series Inverter/Charger and all appropriate sections of this guide and the Xantrex TR Series Inverter/Charger Installation Manual (Part #: 975-0367-01-01). Be sure to read all instructions and cautionary markings for any equipment attached to this unit.
2. This unit is designed for indoor use only. Do not expose the Xantrex TR Series Inverter/Charger to rain, snow, or spray.
3. To reduce risk of fire hazard, do not cover or obstruct the ventilation openings. Do not install the Xantrex TR Series Inverter/Charger in a zero-clearance compartment. Overheating may result.
4. Transformerless battery chargers are not to be used with this product family due to the possible overheating and damage to the charger.
5. Use only attachments recommended or sold by the manufacturer. Doing otherwise may result in a risk of fire, electric shock, or injury to persons.
6. To avoid a risk of fire and electric shock, make sure that existing wiring is in good condition and that wire is not undersized. Do not operate the Xantrex TR Series Inverter/Charger with damaged or substandard wiring.

7. Do not operate the Xantrex TR Series Inverter/Charger if it has received a sharp blow, been dropped, or otherwise damaged in any way. If the Xantrex TR Series Inverter/Charger is damaged, see the Warranty section.
8. Do not disassemble the Xantrex TR Series Inverter/Charger. It contains no user-serviceable parts. See Warranty for instructions on obtaining service. Attempting to service the Xantrex TR Series Inverter/Charger yourself will void your warranty and may result in a risk of electrical shock or fire. Internal capacitors remain charged after all power is disconnected.
9. The Xantrex TR Series contains more than one live circuit (batteries and AC line). Power may be present at more than one source or from more than one location. To reduce the risk of electrical shock, disconnect both AC and DC power from the Xantrex TR Series Inverter/Charger before attempting any maintenance or cleaning or working on any circuits connected to the Xantrex TR Series Inverter/Charger. Turning off controls will not reduce this risk.
10. Use insulated tools to reduce the chance of short-circuits when installing or working with the inverter, the batteries, or a PV array.
11. Several diagrams contained within this manual are basic in nature and are included only to depict different installation options. All details may not be shown, and as such, local electrical codes must still be referenced.

Explosive Gas Precautions



WARNING: Explosion Hazard

Working in the vicinity of lead-acid batteries is dangerous. Batteries generate explosive gases during normal operation. Therefore, you must read this guide and follow the instructions exactly before installing or using your Xantrex TR Series Inverter/Charger.

1. This equipment contains components which tend to produce arcs or sparks. To prevent fire or explosion, do not install the Xantrex TR Series Inverter/Charger in compartments containing batteries or flammable materials, or in locations that require ignition-protected equipment. This includes any space containing gasoline-powered machinery, fuel tanks, as well as joints, fittings, or other connections between components of the fuel system.
2. To reduce the risk of battery explosion, follow these instructions and those published by the battery manufacturer and the manufacturer of the equipment in which the battery is installed.

Precautions When Working With Batteries



WARNING: Explosion or Fire Hazard

Follow all instructions published by the battery manufacturer and the manufacturer of the equipment in which the battery is installed.

1. Make sure the area around the battery is well ventilated.
2. Never smoke or allow a spark or flame near the engine or batteries.
3. Use caution to reduce the risk of dropping a metal tool on the battery. It could spark or short circuit the battery or other electrical parts and could cause an explosion.
4. Remove all metal items, like rings, bracelets, and watches when working with lead-acid batteries. Lead-acid batteries produce a short circuit current high enough to weld metal to skin, causing a severe burn.
5. Have someone within range of your voice or close enough to come to your aid when you work near a lead-acid battery.
6. Have plenty of fresh water and soap nearby in case battery acid contacts skin, clothing, or eyes.
7. Wear complete eye protection and clothing protection. Avoid touching your eyes while working near batteries.
8. If battery acid contacts skin or clothing, wash immediately with soap and water. If acid enters your eye, immediately flood it with running cold water for at least twenty minutes and get medical attention immediately.
9. If you need to remove a battery, always remove the grounded terminal from the battery first. Make sure all accessories are off so you don't cause a spark.
10. Always use identical types of batteries.
11. Never install old or untested batteries. Check each battery's date code or label to ensure age and type.
12. Batteries are temperature sensitive. For optimum performance, they should be installed in a stable temperature environment.
13. Always recycle old batteries. Contact your local recycling center for proper disposal information.

Regulatory

The Xantrex TR Series Inverter/Charger 120 Vac/60 Hz models are CSA Certified to appropriate US and Canadian standards. The 230 Vac/50 Hz models have been marked with the CE designation for European countries. See "Safety and Electromagnetic Compatibility Specifications" on page A-5 for more detailed information.

The Xantrex TR Series Inverter/Charger is intended to be used for residential or commercial applications. Do NOT use this unit for applications for which it is not listed (for example, land vehicles or marine craft). It may not comply with the safety code requirements or could possibly present other operational or safety hazards.

FCC Information for the User

The Xantrex TR Series Inverter/Charger has been tested and found to comply with the limits for a Class B digital device, pursuant to part 15 of the FCC Rules. These limits are designed to provide reasonable protection against harmful interference when the equipment is operated in a residential environment. This equipment generates, uses and can radiate radio frequency energy and, if not installed and used in accordance with this Operation Manual, may cause harmful interference to radio communications. However, there is no guarantee that interference will not occur in a particular installation. If this equipment does cause harmful interference to radio or television reception, which can be determined by turning the equipment on and off, the user is encouraged to try to correct the interference by one or more of the following measures:

- Reorient or relocate the receiving antenna
- Increase the separation between the equipment and the receiver
- Connect the equipment into a circuit different from that which the receiver is connected
- Consult the dealer where the equipment was purchased or an experienced radio/ TV technician for help

Contents

IMPORTANT SAFETY INSTRUCTIONS	vii
1 Introduction	
Introduction	1-2
Features	1-3
AC Side	1-4
DC Side	1-5
Optional Equipment	1-5
Remote on/off Switch	1-5
DC Conduit Box	1-5
2 Operation	
Front Panel	2-2
User Interface	2-2
Service Control Interface	2-5
Over Discharge Protection (ODP)	2-8
Setting the Search Mode Threshold	2-9
Stacking Interface	2-10
Remote Control	2-10
Start-up	2-11
Charge Mode	2-12
3-Stage Charging Process	2-12
Standby Mode	2-13
OFF Mode	2-13
Equalize Charging	2-13
3 Troubleshooting	
Troubleshooting the Xantrex TR Series	3-2
Problem Loads	3-8
A Specifications	
Safety and Electromagnetic Compatibility Specifications	A-5
Warranty and Return Information	WA-1

Figures

Figure 1-1	Front Panel Features	1-3
Figure 1-2	AC Side of the Xantrex TR Series	1-4
Figure 1-3	DC Side of the Xantrex TR Series	1-5
Figure 2-1	Front Panel User Interface	2-2
Figure 2-2	Removing the Service Access Cover	2-5
Figure 2-3	Front Panel Control Interface	2-6
Figure 2-4	Automatically Calculated Discharge Cutoff Voltage per Cell	2-8
Figure 2-5	Search Mode Potentiometer Adjustment	2-10

Tables

Table 1-1	Supplemental Circuit Breaker Sizing	1-4
Table 2-1	Battery Charge Profiles	2-7
Table 3-1	Error Codes	3-2
Table 3-2	Troubleshooting the Xantrex TR Series	3-6
Table A-1	Electrical Specifications - 120 Vac/60 Hz Models	A-2
Table A-2	Electrical Specifications - 230 Vac/50 Hz Models	A-4
Table A-3	Environmental Specifications	A-5

1

Introduction

Chapter 1, "Introduction" contains information about the features and functions of the Xantrex TR Series Inverter/Charger.

Introduction

Thank you for purchasing the Xantrex TR Series Inverter/Charger from Schneider Electric. The Xantrex TR Series is one of the finest inverter/chargers on the market today, incorporating state-of-the-art technology and high reliability.

The inverter features an AC pass-through circuit, powering your home appliances from utility or generator power while charging the batteries. When utility power fails, the battery backup system keeps your appliances powered until utility power is restored. Internal protection circuits prevent over-discharge of the batteries by shutting down the inverter when a low battery condition occurs. When utility or generator power is restored, the inverter transfers to the AC source and recharges the batteries.

The front panel features indicator lights and a user interface display for reading system status, and controls to customize the inverter settings for your battery bank.

The Xantrex TR Series is an economical product designed to provide a reliable supply of electricity to all the essential circuits in the home or business during a power outage. The critical loads can be powered for hours or days, depending on the size of the system battery bank. When utility grid power returns, the batteries are quickly recharged to ensure they will be ready to supply backup power during the next outage.

Accessories allow the Xantrex TR Series to also serve as a central hub of a renewable energy system.

Modified Sine Wave Power	The Xantrex TR Series provide a modified sine wave output which operates most AC appliances and equipment.
Battery Charger/ AC Transfer Relay	The inverter/charger includes a 3-stage battery charger designed to recharge batteries in the shortest possible time. Once batteries are fully charged, the Xantrex TR Series will go into standby mode to reduce the energy draw from the utility. The built-in, fully automatic AC transfer relay automatically transfers power from the utility to the inverter and handles a maximum rating of 30 A of current at 120 Vac or 15 A of current at 230 Vac.
Simplicity	The Xantrex TR Series is simple to operate. All inverter and battery charger controls are located on the front panel.
High Efficiency	The inverter/charger operates at over 90% efficiency through most of its power range in Invert-mode.
Low Power Consumption	Xantrex TR Series uses less than 2 watts of power while in standby mode and in search mode, it consumes less than 4.7 watts of power.
Power Factor Correction	The Xantrex TR Series is power factor corrected to reduce power loss and maximize efficiency.

Features

The following sections illustrate the features of the Xantrex TR Series. Figure 1-1 shows the features of the front side of the Xantrex TR Series and identifies the AC side from the DC side.

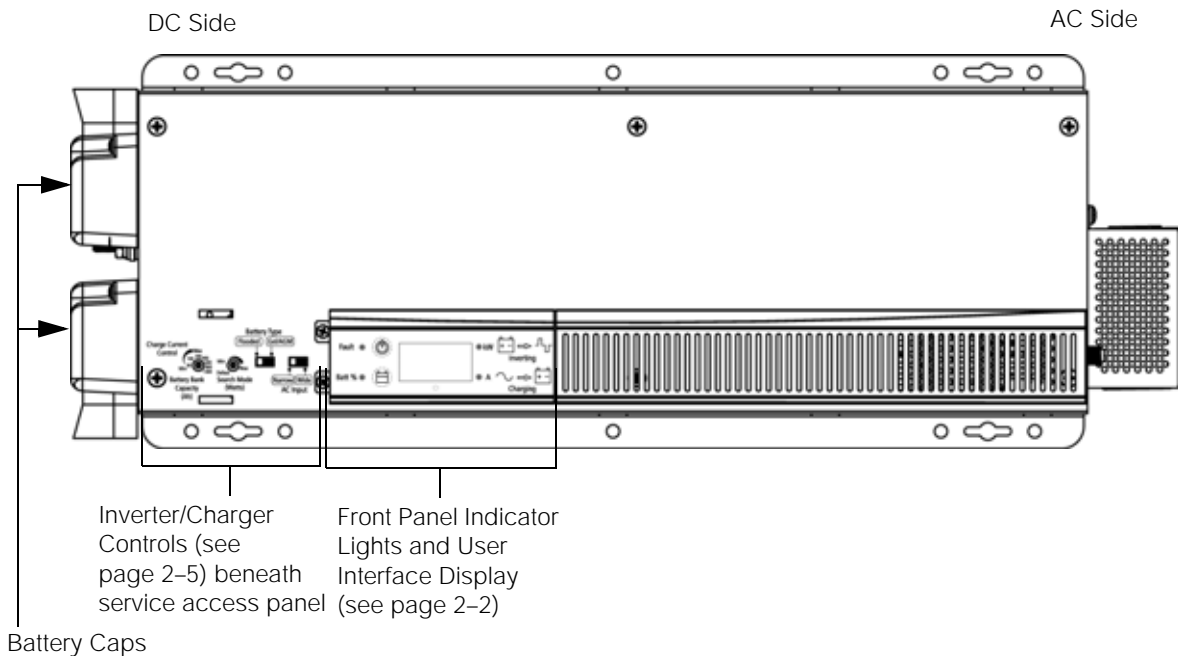

Figure 1-1 Front Panel Features

AC Side

The AC side of the Xantrex TR Series has one breaker for pass-through AC input (30 A max and 15 A max for 120 Vac/60 Hz and 230 Vac/50 Hz models respectively), which protects the internal pass-through relay and wiring from the AC output to the user-installed branch circuit breaker. There is also a second breaker for charger AC input (30 A max and 15 A max for 120 Vac/60 Hz and 230 Vac/50 Hz models respectively), which protects the internal charge relay and the components on the AC filter board. The breakers are rated for the maximum charge rate and pass-through current allowed according to the rating of the internal relay. Appropriately sized branch-rated circuit breakers must be installed directly on the AC output circuits to protect output circuits and wiring. Consult your local electrical code for selection of these branch-rated output circuit breakers.

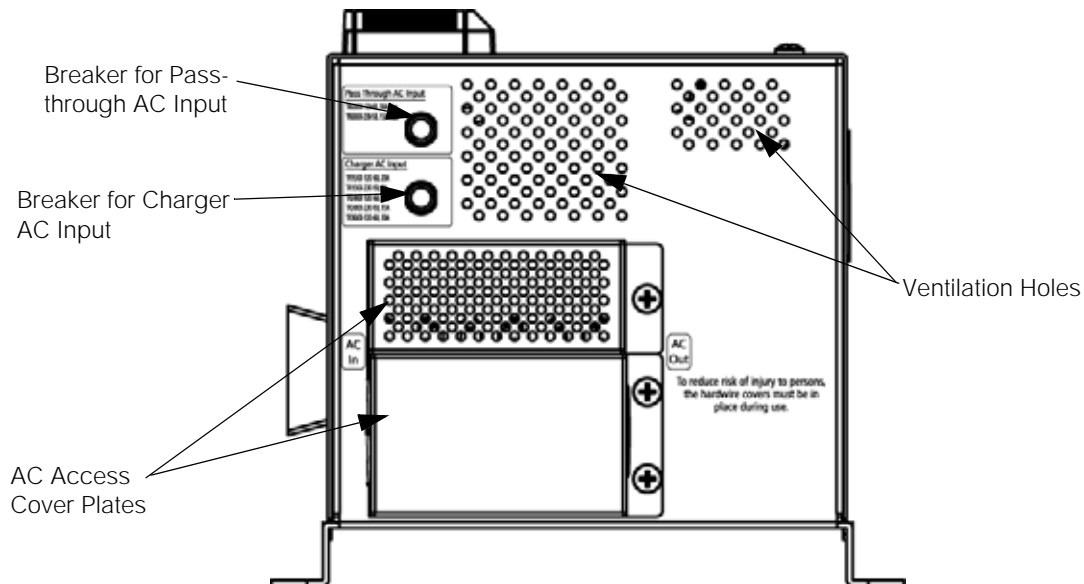

Figure 1-2 AC Side of the Xantrex TR Series

Table 1-1 Supplemental Circuit Breaker Sizing

Model	AC Pass-through Circuit Breakers	Battery Charger Circuit Breakers
Xantrex TR1512 120 60	30 amps	20 amps
Xantrex TR2412 120 60	30 amps	30 amps
Xantrex TR1524 120 60	30 amps	20 amps
Xantrex TR2424 120 60	30 amps	30 amps
Xantrex TR3624 120 60	30 amps	30 amps
Xantrex TR1512 230 50	15 amps	8 amps
Xantrex TR1524 230 50	15 amps	8 amps
Xantrex TR2424 230 50	15 amps	15 amps

DC Side

The DC side of the Xantrex TR Series has the equipment ground lug, the positive (+) battery terminal, and the negative (-) battery terminal plus the COM port and battery temperature sensor port.

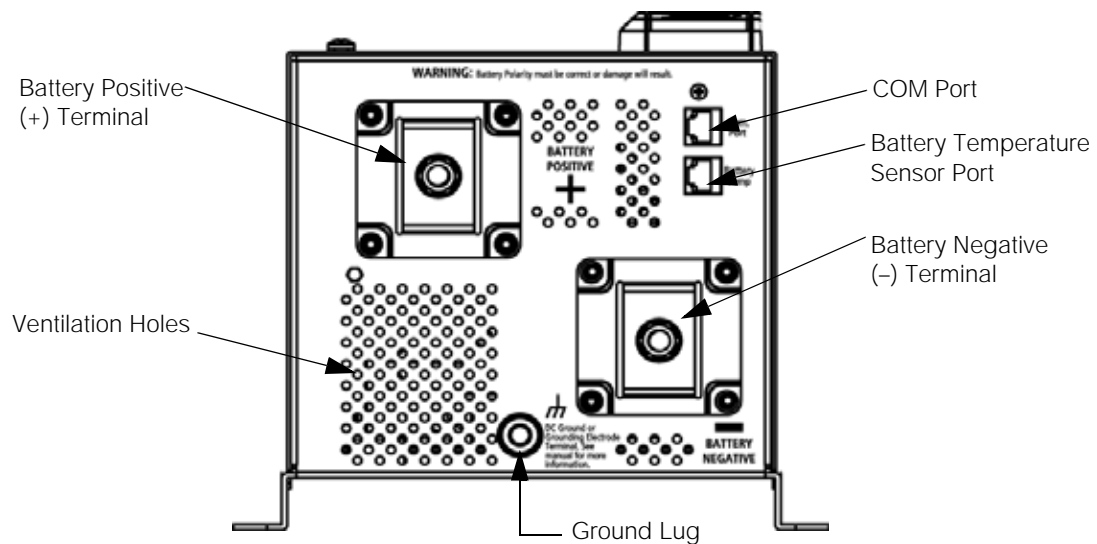

Figure 1-3 DC Side of the Xantrex TR Series

Optional Equipment

The following options are available for the Xantrex TR Series Inverter/Chargers.

Remote ON/OFF Switch

The XANTREX TR RS ON/OFF SWITCH (manufacturer part number: 989-1060) allows the inverter to be switched ON or OFF remotely and includes an LED status indicator.

DC Conduit Box

The XANTREX TR CB (manufacturer part number: 989-1050) connects to the DC side of the inverter and accepts a DC conduit run.

2

Operation

Chapter 2, "Operation" contains information about how to operate the Xantrex TR Series Inverter/Charger.

Front Panel

The front panel of the Xantrex TR Series is equipped with a user interface, comprised of indicator lights and a display screen to provide inverter/charger status at a glance.

The front panel is also equipped with a control interface behind an access panel intended for set-up and service use only.

Below the display screen there is a pin-hole type push button to transition the Xantrex TR Series into battery equalize mode.

User Interface

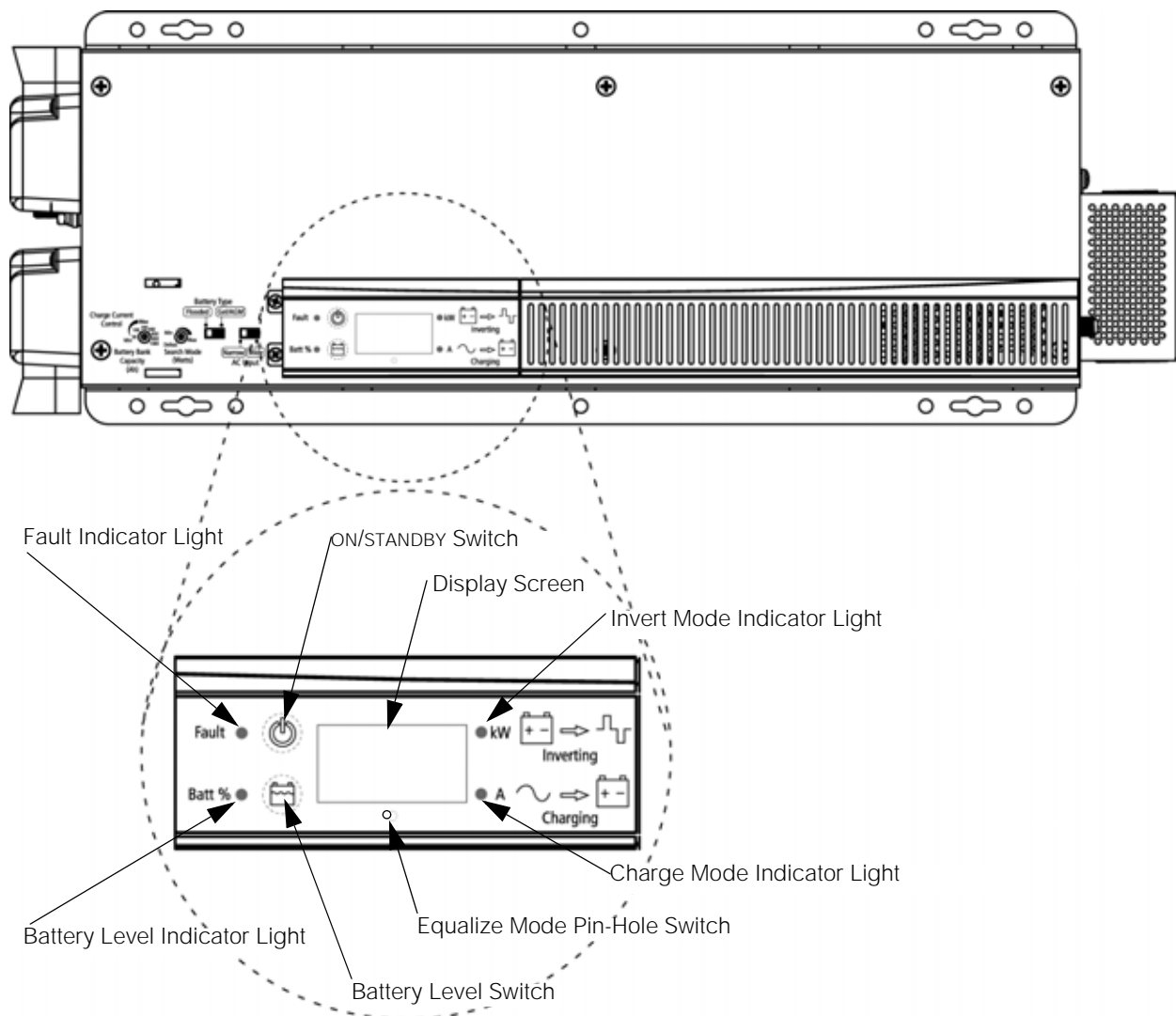

Figure 2-1 Front Panel User Interface

User Interface Item	Description
ON/STANDBY Switch	<p>Press to transition the Xantrex TR Series from OFF mode to ON. Xantrex TR Series restarts in invert mode (if only DC power present) or charge mode (AC and DC power present).</p> <p>Press to transition the Xantrex TR Series from any stage of charge mode, invert mode or standby mode to OFF.</p> <p>Press to clear faults and warnings.</p> <p>Press during low battery warning to disable the ODP during ODP-enabled low battery warning. (see "Over Discharge Protection (ODP)" on page 2–8).</p>
Display Screen	<p>Displays the power in kW when the Xantrex TR Series is in invert mode.</p> <p>Displays the current in Amps when the Xantrex TR Series is in charge mode.</p> <p>Displays the battery level in % when the battery level switch is pressed.</p> <p>Alternately flashes the warning code and either power or current (depending on mode) when there is an active warning (see Table 3-1 on page 3–2).</p> <p>Displays the fault code when there is an active fault (see Table 3-1 on page 3–2).</p> <p>Displays "---" when the Xantrex TR Series is in standby mode (charge mode indicator light is solid green) or when the Xantrex TR Series is OFF (charge mode indicator light is not illuminated).</p> <p>Displays "---" when the Xantrex TR Series has been manually transitioned to OFF Mode from charge mode (charge mode indicator light is not illuminated).</p> <p>Display is blank when the Xantrex TR Series has been manually transitioned to OFF Mode from invert mode (no indicator lights are illuminated).</p>
Invert Mode Indicator Light	<p>Indicator light is illuminated when the Xantrex TR Series is in invert mode.</p> <p>Indicator light is flashing when the Xantrex TR Series is load sensing.</p> <p>Indicator light is off when the Xantrex TR Series is in charge mode.</p> <p>Indicator light is off when the Xantrex TR Series has been manually transitioned to OFF Mode.</p>

User Interface Item	Description
Charge Mode Indicator Light	<p>Indicator light is illuminated orange when the Xantrex TR Series is in the bulk stage of charge mode.</p> <p>Indicator light is flashing orange when the Xantrex TR Series is in the absorption stage of charge mode.</p> <p>Indicator light is illuminated green when the Xantrex TR Series is in the float stage of charge mode or when the unit is in standby mode (in this case the display shows "---" instead of the current in Amps).</p> <p>Indicator light is illuminated red when the Xantrex TR Series has entered an equalize cycle but is in the bulk or absorption stage of the cycle.</p> <p>Indicator light is flashing red when the Xantrex TR Series has entered an equalize cycle and is currently equalizing the batteries.</p> <p>Indicator light is off when the Xantrex TR Series is in invert mode.</p> <p>Indicator light is off when the Xantrex TR Series has been manually transitioned to OFF Mode.</p>
Equalize Mode Pin-Hole Switch	<p>Press for at least 5 seconds, using a paper clip, to transition the Xantrex TR Series into equalize mode (see "Equalize Charging" on page 2-13).</p> <p>During equalize mode press for at least 5 seconds, using a paper clip, to cancel equalization.</p>
Battery Level Switch	<p>Press to show the current battery level in % on the display screen.</p>
Battery Level Indicator Light	<p>Indicator light is illuminated when the battery level switch is being pressed.</p>
Fault Indicator Light	<p>Indicator light flashes red when the Xantrex TR Series has entered a warning condition.</p> <p>Indicator light is illuminated red when the Xantrex TR Series has entered a fault condition.</p>
Audible Alarm	<p>Beeps when any of the front panel switches are pressed.</p> <p>Beeps when the battery temperature sensor is plugged in.</p> <p>Beeps at 1 second intervals in the event of a warning</p> <p>Beeps continuously in the event of a fault (press ON/STANDBY switch to clear the fault and stop the audible alarm).</p>

Service Control Interface

There are several service controls on the inverter's front panel, beneath the service access panel, that provide adjustments for the battery charger to accommodate battery type and size, AC input stability and energy saving preferences. These controls are intended for service users only and should be set once during initial setup.

To remove the service access panel:

1. Squeeze the two tabs on the sides of the service access cover (① in Figure 2-2).
2. Pull the cover off to allow access to the control interface (② in Figure 2-2).
3. Replace the cover after initial setup.



WARNING: Fire hazard

The service access panel must always remain in place during unit operation and should always be replaced following servicing.

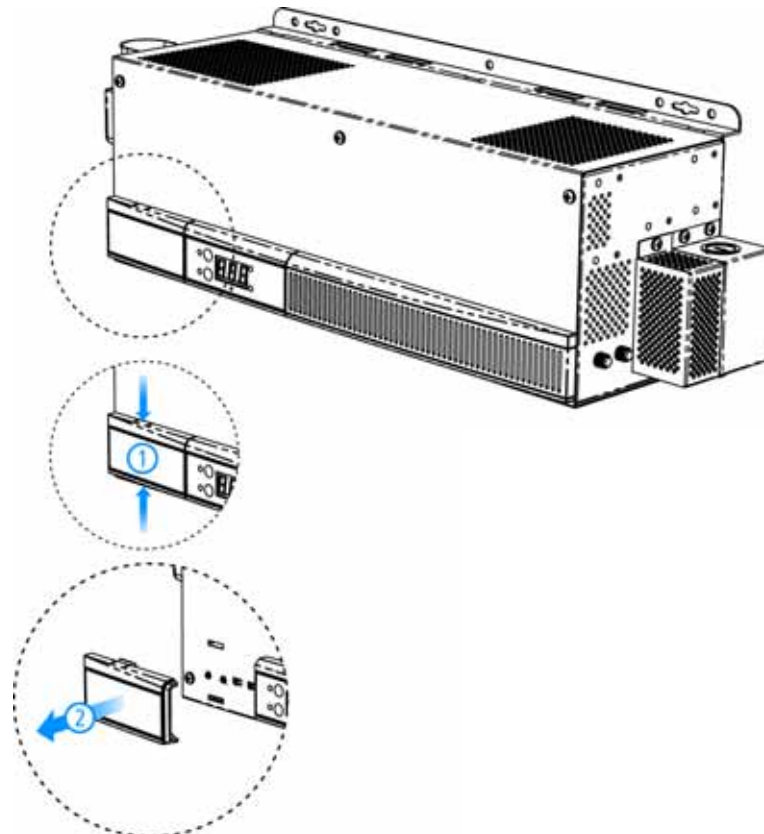

Figure 2-2 Removing the Service Access Cover

Once the service access panel is removed, the service controls may be modified to suit the specific configuration.

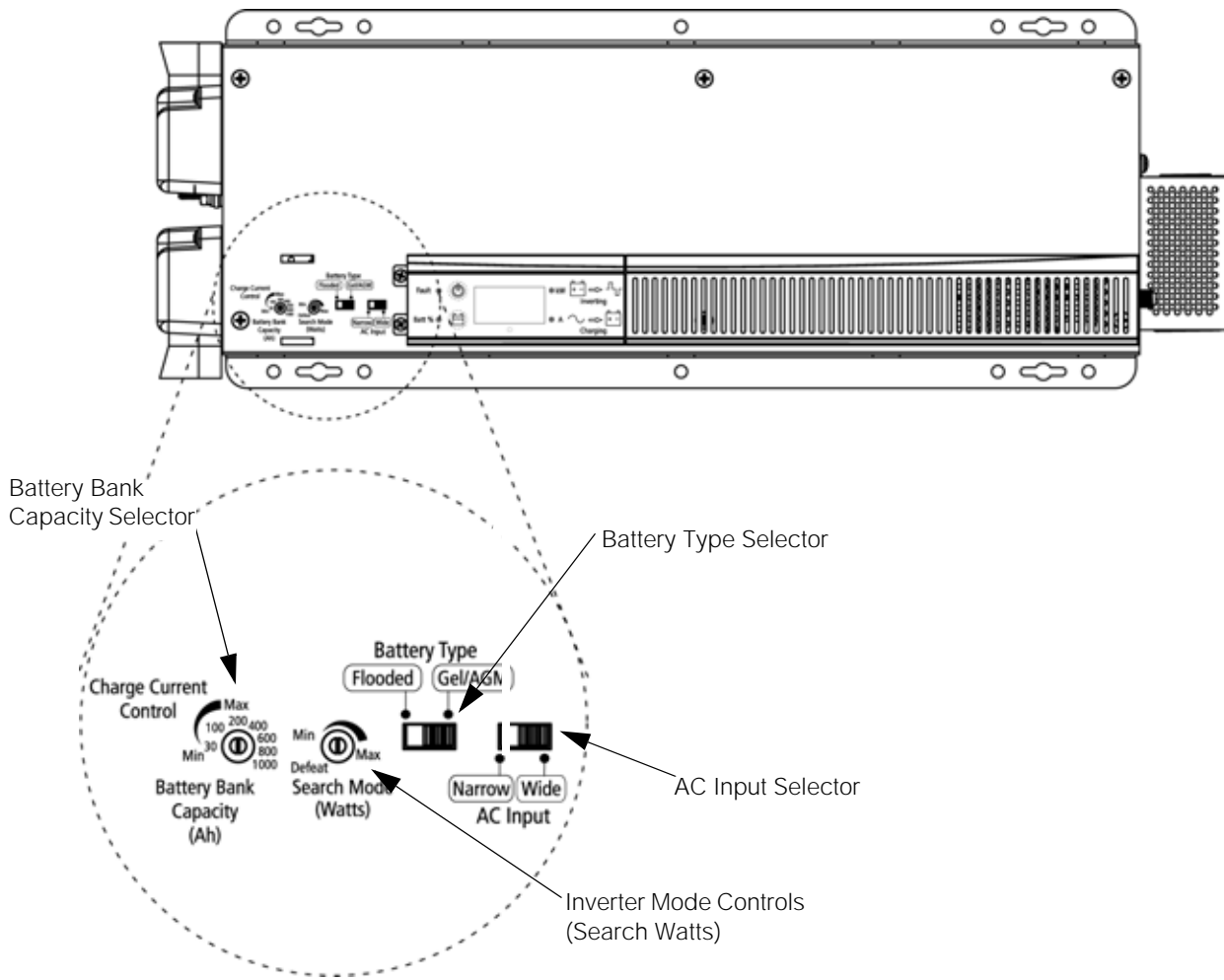

Figure 2-3 Front Panel Control Interface

Service Control Interface Item	Description
AC Input Selector	Move the 2 position slide switch to set either narrow or wide AC input. Choose the narrow selection for a more normal range of AC sources, down to 95 Vac (180 Vac for 230 Vac/50 Hz units). Choose the wide selection if you need to accept an extremely low AC source, down to 65 Vac (120 Vac for 230 Vac/50 Hz units).
Battery Type Selector	Move the 2 position slide switch to set either flooded batteries or gel/AGM batteries. See caution note below. During equalize mode, move the switch briefly to gel/AGM and back to Flooded to cancel the equalization.

Service Control Interface Item	Description
Search Mode Potentiometer	<p>Use a small jeweller's style flat-head screwdriver to adjust the current threshold required to bring the inverter out of search mode into full inverter operation.</p> <p>With search mode enabled, the inverter minimizes energy consumption by pulsing the AC output looking for an applied load, rather than remaining at full inverter operation when there is no load. Disabling the threshold by setting the potentiometer fully counter-clockwise to the Defeat setting causes the inverter to remain on (in full power operation) even when there is no applied load.</p> <p>See "Setting the Search Mode Threshold" on page 2-9.</p>
Battery Bank Capacity Selector/ Charge Current Control	<p>Use a small jeweller's style flat-head screwdriver to adjust the potentiometer to match the Ah of your battery bank. The setting allows the inverter to calculate the over-discharge protection values and also the transition criteria between Bulk, Absorption and Float stages of charge mode.</p> <p>The potentiometer should be adjusted as close as possible to the actual capacity of the battery bank for optimum charging. If your bank is greater than 1000 Ah, then set the potentiometer to 1000 Ah.</p> <p>When set at 200 Ah or above, the charge current control is automatically at maximum. For settings between 30 Ah and 200 Ah, the charge current is linearly determined between 14% and 100% of the maximum charge rate.</p> <p>Important: If using dual inverters configurations, set each charger for half the value.</p>



CAUTION: Equipment damage

Batteries requiring different charging voltages than the Xantrex TR Series provides may be damaged if used with this unit. Cross-reference the information in Table 2-1 with the information provided with your battery.

Table 2-1 Battery Charge Profiles

Profile	Description	Bulk/ Absorption		Equalize		Float	
		12V	24V	12V	24V	12V	24V
Flooded	Flooded lead acid	14.6	29.2	16	32	13.4	26.8
Sealed	Gel/AGM lead acid	14.1	28.2	N/A	N/A	13.5	27.0

Over Discharge Protection (ODP)

Over discharge protection shuts down the inverter at a specified voltage (low battery cutoff) to protect the batteries from over discharge damage. ODP is automatically enabled on the Xantrex TR Series unit. The inverter circuitry calculates the lowest (safe) DC voltage (leaving approximately 30-40% battery capacity) based on the position of the Battery Capacity Knob and the amount of load current on the inverter's output. With a higher load, the inverter's calculation decreases the low cutoff. With higher battery capacity, it increases the cutoff. Under no-load conditions, this level is typically between 11.8 and 12.0 Vdc (for a 12-volt battery bank).

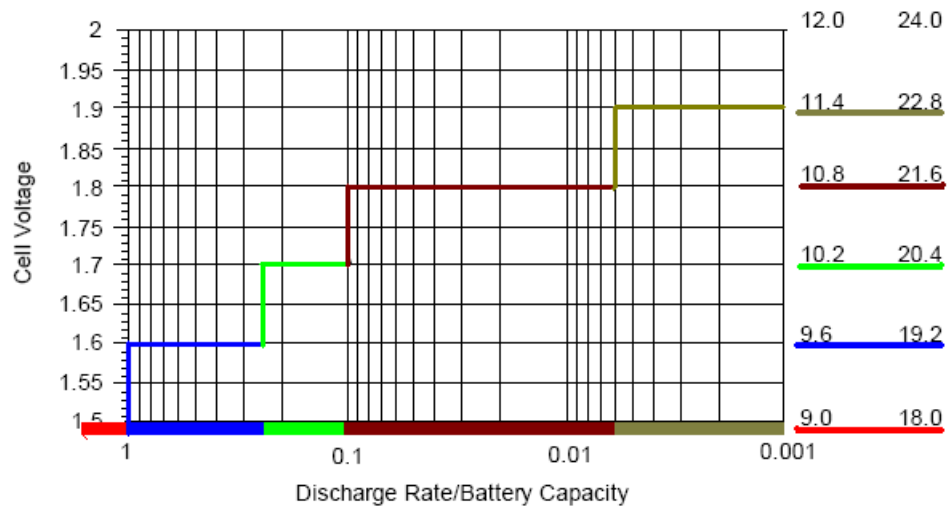

Figure 2-4 Automatically Calculated Discharge Cutoff Voltage per Cell

In the event of a low battery warning (*F08*), the ODP may be temporarily disabled by pressing the ON/STANDBY switch. This enables the unit to continue functioning until the batteries reach the default low battery threshold or until the user manually stops inverting and charges the battery.



CAUTION: Battery damage

Allowing a battery to reach the default low battery threshold is not recommended and may damage the battery. Schneider Electric recommends that if you disable the ODP, you stop inverting and charge the battery before the *F09* default low battery warning.

If the Xantrex TR Series turns itself off (if the warning has progressed to a fault) or if the user manually stops inverting, the ODP will be automatically re-enabled as soon as the unit is in invert mode again. With ODP enabled, the Xantrex TR Series will restart at a battery voltage of 12.5 V (12 V units) or 25 V (24 V units). With ODP disabled, the Xantrex TR Series will restart at a battery voltage of 11.5 V (12 V units) or 23 V (24 V units).

Setting the Search Mode Threshold







To set the Search Mode Watts:

1. Remove the AC input source from the inverter. The inverter switches to battery operation. Ensure all inverter supported appliances are switched OFF.
2. Turn the potentiometer completely clockwise (to MAX).
3. Switch on the load which will trigger the inverter to full power. This could be a lamp located in a convenient location if the power goes out. The light may flicker as the inverter searches the line for a load. The invert mode indicator light blinks 2-3 times a second, indicating the inverter is in Search Mode.
4. Slowly turn the potentiometer counter-clockwise (toward MIN) when the proper setting is found, the lamp and the invert mode indicator light will illuminate.
5. Turn the lamp OFF for a moment. The inverter should switch back to Search Mode. Turn the lamp ON. Ensure the inverter comes out of Search Mode. Adjust the potentiometer up or down as necessary.

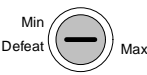
Important: The Search Mode only activates when the unit is operating in invert mode (from batteries) to prevent unnecessary battery discharge when electrical power is not required. If the inverter is supporting loads that must constantly be powered, turn the search mode OFF by setting the potentiometer fully counter-clockwise (CCW) to the DEFEAT position.

Important: Some loads constantly draw power even though they are switched OFF, such as TVs with instant-ON circuits, microwaves with digital displays, VCRs. It is best to operate these devices from another circuit, install a switch to turn these OFF completely or don't use the Search Mode.

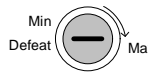
Important: When the Search Mode is used with series stacked inverters, only 120 Vac loads connected to the "master" inverter will bring the unit out of the search mode.

Potentiometer Setting						
120 V Model Load Setpoint	Disabled	5W	30W	60W	120W	240W
230 V Model Load Setpoint	Disabled	10W	60W	120W	240W	480W

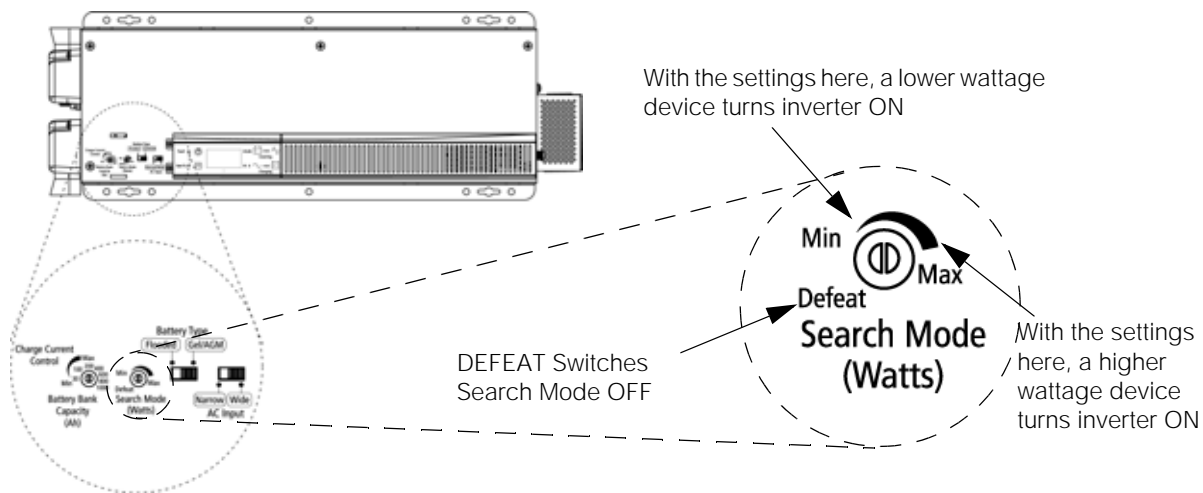

Figure 2-5 Search Mode Potentiometer Adjustment

Stacking Interface

Important: Only 120 Vac/60 Hz units can be used in a stacked configuration.

Whenever two Xantrex TR Series inverters are used in a series (stacked) configuration, one unit (primary) controls the other unit (secondary). Which ever unit is switched ON becomes the primary and automatically switches on the secondary inverter and ensures the secondary's output is 180° out of phase for 240 Vac operation. Both units can charge the batteries or provide battery backup power during a utility outage.

To operate stacked inverters:

1. Switch on the inverter designated as primary or INVERTER 1 (L1).
2. The inverter designated as secondary or INVERTER 2 (L2) will automatically turn on.

The inverter should be providing 120 VAC/240 VAC to the sub-panel.

The stacked inverter system is now ready for use.

Once stacked, the Xantrex TR Series units will operate the same as a single unit. In the event of an error, both units will shut down and the individual unit with the error will show the error code on the front panel display.

Remote Control

Xantrex TR Series are designed to operate with a XANTREX TR RS ON/OFF SWITCH remote control unit. The remote incorporates a membrane switch with a single red indicator light display combination to start and stop the inverter, and provides overall system operating status. Refer to the manual shipped with the XANTREX TR RS ON/OFF SWITCH for indicator light flash sequences and how to interpret them.

The remote control must be connected prior to switching the inverter ON; otherwise, the micro-controller will not recognize (or respond to) the remote. If the remote is not recognized, switch the inverter to STANDBY and then ON using the inverter's front panel ON/STANDBY switch.

Start-up

Once the inverter is properly connected to the batteries, AC source, and loads (using a sub-panel) the inverter is ready for operation. Recheck the controls and ensure they are in the proper position. Recheck all wiring and ensure it is correct.

Starting the inverter:

1. Apply DC power to the inverter by switching on the DC disconnect circuit breaker and then pressing the ON/STANDBY switch once. The inverter will go through a self-test.
 - each of the indicator lights will flash in sequence
 - the cooling fan will turn on momentarily
 - the transfer relay will switch
 - the temperature sensors will be checked for open or short circuit
2. After the self-test the unit will start inverting.
3. Apply AC power to the inverter.
4. The inverter starts charging the batteries in the Bulk mode, indicated by the Charge Mode indicator light illuminating orange. It takes about 15 seconds for the unit to transition from invert mode to charge mode after the application of qualified AC.
5. Using a true RMS AC voltmeter, check the output voltage of the inverter. This voltage can be checked at either the AC terminal block or in the sub-panel (between the line and neutral). The voltage should be approximately 120 Vac (120 Vac/50 Hz models) or 230 Vac (230 Vac/60 Hz models).
6. Switch the AC disconnect circuit breaker to OFF. The inverter will go into invert mode (if a sufficient load is applied to the AC output while in the search mode). The Invert Mode indicator light will illuminate indicating the inverter is active. The voltage on the AC output of the inverter will remain the same as above ($\pm 5\%$ maximum) except ~ 104 Vac under no load conditions for power savings or ~ 207 Vac under no load conditions for power savings for 230 vac/60Hz models. (Non-true RMS meters probably will not measure accurately).

Important: If the inverter is in Search Mode and a sufficient load is not available to bring the inverter up to full voltage, turn the Search Mode potentiometer fully counter-clockwise to defeat the search function.

7. Reapply the AC power by switching the AC disconnect to ON. Allow the batteries to fully recharge.

Important: The unit will not use renewable energy for AC output as long as AC input (utility or generator) is available to the inverter.

Charge Mode

3-Stage Charging Process

The charging cycle uses a 3-stage charging process to maintain the batteries. Whenever nominal AC is present at the inverter's input and the inverter is on, it passes power through to the connected load and begins charging the batteries, indicated by the Charge Mode indicator light.

Bulk Charge

Bulk charge is the first stage in the charging process and provides the batteries with a controlled, constant current. The Charge Mode indicator light is illuminated orange. Once the battery voltage rises to the bulk voltage threshold, the charger then switches to the absorption mode.

Absorption Charge

Absorption charge is the second stage of battery charging and provides the batteries a controlled, constant voltage. The Charge Mode indicator light is flashing orange.

During this stage the current supplied to the batteries slowly decreases. When the current equals the programmed return amps value (5% of the battery capacity setting) set with the Battery Bank Capacity potentiometer, the charger switches to the third stage—float.

Important: If there are DC loads connected to the battery, the current may never decrease to the level to initiate the float stage. The inverter/charger incorporates a timer circuit which starts counting when AC voltage is applied. The length of time is variable based on the amp-hours of the battery bank connected. To ensure that the charger does not stay indefinitely in the absorption charge mode, the timer automatically switches to the float charge mode.

Float Charge

Float charge, the final stage of battery charging, maintains a charge to the batteries for 1 hour as long as AC is present on the inverter's input. Float charging reduces battery gassing, minimizes watering requirements (for flooded batteries) and ensures the batteries are in a constant state of readiness. The Charge Mode indicator light is illuminated green.

After 1 hour at float charge, the Xantrex TR Series will transition to Standby Mode.

Standby Mode

The Xantrex TR Series will transition to the Standby (charger OFF) Mode after 1 hour in the float stage. In standby, the Charge Mode indicator light is solid green and the display screen shows "---".

A new charge cycle will be initiated if the battery voltage drops below 12.5 Vdc (for 12 V models) or 25 Vdc (for 24 V models) while in Standby Mode. You can manually initiate a new charge cycle while in Standby Mode by pressing the ON/STANDBY switch once, to transition the Xantrex TR Series to OFF, then pressing the ON/STANDBY switch again.

If qualified AC power becomes not available while the Xantrex TR Series is in Standby Mode, it will automatically transition to Invert Mode and begin taking power from the batteries.

OFF Mode

You can manually transition the Xantrex TR Series to OFF while in Standby Mode, Invert Mode or any stage of Charge Mode by pressing the ON/STANDBY switch once. In OFF Mode, no indicator lights are illuminated and the display screen shows "---" if qualified AC is present, or the display screen is blank if qualified AC is not present.

In OFF Mode the Xantrex TR Series passes-through qualified AC voltage only; if qualified AC power becomes not available while the Xantrex TR Series is in OFF Mode, it will not automatically transition to Invert Mode. You can manually initiate a new charge cycle or initiate inverting while in OFF Mode by pressing the ON/STANDBY switch once.

Equalize Charging

Equalize charging is a special mode of battery charging. During use, the battery's cells can become unequal in the voltage and current they can deliver, which effects the run time. Equalizing stirs up the electrolyte, distributing the acid, and removing the sulfate from the plates. Equalizing the batteries every month or two (depending on usage) prolongs the life of the batteries and provides better battery performance.

The Xantrex TR Series will enter a Bulk and Absorption cycle first, before transitioning to Equalize Mode. Once the Xantrex TR Series transitions to an equalize cycle, and until the equalize voltage (16.0Vdc/32.0Vdc) is reached, the charging current is determined by the battery Ah set-point as described on page 2-7. After reaching the equalize voltage, the equalize cycle will continue for one hour equalizing batteries at a constant voltage (16.0Vdc/32.0Vdc). The Charge Mode indicator light is illuminated solid red during Bulk and Absorption of an equalize cycle and is flashing red during Equalize Mode.

If the batteries are successfully equalized, the Xantrex TR Series will switch to Float Mode and continue with normal operation.

If the equalize voltage set-point is not reached within an hour of the equalize cycle starting, the Xantrex TR Series will switch to Float Mode and continue with normal operation while displaying the Failed to Equalize Warning (F 14). This code is only a warning that never transitions into a fault mode. It is active until it is cleared by pressing the ON/STANDBY switch once. If the Xantrex TR Series fails to equalize the batteries, try another Equalize Cycle and if it fails to equalize again check and replace your batteries as needed.



CAUTION: Explosion Hazard

Only unsealed or vented batteries should be equalize charged. Only flooded batteries (not gel/AGM batteries) can be equalized. Since Hydrogen and oxygen gases are produced when equalized, provide adequate ventilation and remove all sources of ignition to prevent explosion. Remove DC loads while equalizing as they can be damaged by the higher battery voltage.

To transition the Xantrex TR Series to Equalize Mode:

1. Remove all DC loads connected to the batteries.
 2. Ensure the Battery Type Selector switch is set to flooded (see Figure 2-3 on page 2-6).
 3. Remove all battery vent caps.
 4. Check the battery water level, it should be just over the top of the plates (do not overfill). Use only distilled water for filling batteries.
-

Important: Recheck the water level after equalize charging and refill if necessary.

5. Press the Equalize Mode pin-hole type switch for at least 5 seconds, using a paper clip or something similar, to put the Xantrex TR Series into equalize mode.

If another equalize cycle is required after equalization has finished, press the Equalize Mode switch again for 5 seconds.

Important: See the Schneider Electric website for the Application Note titled "*Battery Banks for Inverter Systems*" for additional information on battery care and maintenance.

To cancel Equalize Mode:

1. Press the Equalize Mode pin-hole type switch for at least 5 seconds, using a paper clip or something similar.

or

2. Move the Battery Type Selector Switch briefly to gel/AGM and then back to flooded.

3

Troubleshooting

Chapter 3, "Troubleshooting" contains information about how to troubleshoot possible error conditions while using the Xantrex TR Series Inverter/Charger.

Troubleshooting the Xantrex TR Series

Table 3-1 shows the possible error codes on the display screen and the description of the fault or warning.

Table 3-2 provides a list of possible error conditions that may occur, their possible causes, and possible solutions to resolve the error condition.

When the Xantrex TR Series is in Warning status, the Fault LED is flashing red, the audible alarm is beeping at one second intervals and the display is alternately showing the error code and the power or current (depending on Invert or Charge mode of the inverter).

When the Xantrex TR Series is in Fault status, the Fault LED is solid red, the audible alarm is beeping continuously and the display is continuously showing the error code.

If the reason for the error is corrected while the Xantrex TR Series is still in Warning status, not Fault status, then the unit will automatically clear the warning and restart. If the error has progressed to Fault status then the unit will shut down and will have to be manually restarted.

To clear a fault and restart the unit:

1. Press the ON/STANDBY switch once to clear the error.
2. Press the ON/STANDBY switch again to manually turn the Xantrex TR Series on.

Table 3-1 Error Codes

Error Code	Fault or Warning	Description	Solution
<i>F01</i>	Fault	Fan is locked or disconnected.	This is a mechanical blockage of the fan. Ensure the Xantrex TR Series is fully OFF. Carefully inspect for foreign objects lodged in the fan and remove as necessary. Manually restart unit. If condition persists, contact your authorized service centre.
<i>F02</i>	Warning	The Xantrex TR Series is over heating. Unit is still functioning, but if the over heating is not corrected in 40 seconds the warning will become a fault.	Allow the Xantrex TR Series to cool. Improve ventilation around the unit or install in a cooler location.
<i>F02</i>	Fault	The <i>F02</i> warning has persisted until it has become a fault. The Xantrex TR Series has stopped inverting or charging and is waiting to cool down before automatically restarting.	Allow the Xantrex TR Series to cool. Improve ventilation around the unit or install in a cooler location.

Table 3-1 Error Codes

Error Code	Fault or Warning	Description	Solution
<i>F03</i>	Warning	<p>The Xantrex TR Series has not detected a battery temperature sensor during startup test. After 5 seconds, this warning will automatically clear.</p> <p>The battery temperature sensor connected to the Xantrex TR Series has an error. Normal inverting and charging is not affected by this warning. The Xantrex TR Series will continue the charge cycle using the last known temperature reading, then it will continue at the default temperature of 25 °C (77 °F).</p>	<p>Either connect a battery temperature sensor, or be aware of the impact of not using one.</p> <p>Press the ON/STANDBY switch once to clear fault.</p> <p>Check the battery temperature sensor connections and replace the battery temperature sensor if necessary.</p>
<i>F03</i>	Fault	<p>The battery temperature sensor connected to the Xantrex TR Series has detected a temperature outside of the safe operating temperature of -20 °C – 60 °C (-4 °F – 140 °F).</p>	<p>Xantrex TR Series has shut down for safety reasons.</p> <p>Check the batteries and adjust location/ventilation of the batteries.</p> <p>Manually restart unit.</p>
<i>F04</i>	Fault	<p>Xantrex TR Series AC transfer relay has failed.</p>	<p>Xantrex TR Series has shut down for safety reasons.</p> <p>Manually restart unit.</p> <p>If condition persists, contact Schneider Electric for service.</p>
<i>F05</i>	Warning	<p>The electrical devices connected to the AC output of the Xantrex TR Series have exceeded the power rating of the unit (either too many devices, or devices with too high power consumption). Unit is still functioning, but if the over load does not self-corrected in 10 seconds the warning will become a fault.</p>	<p>No action required, warning is in place to prevent shutdown in the event of a quick, self-corrected power surge.</p>
<i>F05</i>	Fault	<p>The <i>F05</i> Warning has persisted until it has become a fault. The electrical devices connected to the AC output of the Xantrex TR Series have exceeded the power rating of the unit (either too many devices, or devices with too high power consumption).</p>	<p>Check the power rating of connected electrical devices.</p> <p>Remove electrical devices until the combined power consumption is less than the power level of your Xantrex TR Series (see the table on page iv). Manually restart unit.</p>

Table 3-1 Error Codes

Error Code	Fault or Warning	Description	Solution
<i>F05</i>	Warning	The Xantrex TR Series has been short circuited at the AC output. Unit is still functioning, but if the short circuit does not self-corrected in 10 seconds the warning will become a fault.	No action required, warning is in place to prevent shutdown in the event of a quick, self-corrected short at the inverter output.
<i>F06</i>	Fault	The <i>F05</i> warning has persisted until it has become a fault.	Check connected loads for short circuits. This condition is also present in case of extreme overloading (i.e. when load requires more than 200% of the rated output current).
<i>F07</i>	Fault	The AC side of the Xantrex TR Series is attempting to backfeed to the AC grid as the result of another fault.	Xantrex TR Series has shut down for safety reasons. Manually restart unit. If condition persists, contact Schneider Electric for service.
<i>F08</i>	Warning	At least one connected battery has dropped below the ODP threshold set. Unit is still functioning, but if the low battery is not corrected in 60 seconds the warning will become a fault.	Charge batteries. Reduce AC load. or Press the ON/STANDBY switch once during the 60 second warning to temporarily disable the ODP (see "Over Discharge Protection (ODP)" on page 2-8.
<i>F08</i>	Fault	The <i>F08</i> warning has persisted until it has become a fault. At least one connected battery has dropped below the ODP threshold set.	Charge batteries or Remove all electrical devices taking power from the unit. Manually restart unit in Charge Mode.
<i>F09</i>	Warning	Active only when ODP has been disabled. At least one connected battery has dropped below the default low battery threshold. Unit is still functioning, but if the low battery is not corrected in 30 seconds the warning will become a fault.	Charge batteries. Reduce AC load.

Table 3-1 Error Codes

Error Code	Fault or Warning	Description	Solution
<i>F09</i>	Fault	Active only when ODP has been disabled. The <i>F09</i> warning has persisted until it has become a fault. At least one connected battery has dropped below the default low battery threshold.	Charge batteries or Remove all electrical devices taking power from the unit. Manually restart unit in Charge Mode.
<i>F10</i>	Warning	Input voltage from a connected battery (or a combination of batteries in the bank) is too high for the Xantrex TR Series (battery voltage goes above 15.5 V for 12 V units, or above 31 V for 24 V units). Unit is still functioning, but if the high battery does not self-corrected in 5 seconds the warning will become a fault.	No action required, warning is in place to prevent shutdown in the event of a quick, self-corrected power surge.
<i>F10</i>	Fault	The <i>F10</i> warning has persisted until it has become a fault. Input voltage from a connected battery (or a combination of batteries in the bank) is too high for the Xantrex TR Series (battery voltage goes above 15.5 V for 12 V units, or above 31 V for 24 V units).	Measure the total equivalent battery voltage and replace or remove any that exceed the battery bank size requirements of your Xantrex TR Series (see the table on page iv). Manually restart unit.
<i>F11</i>	Warning	The AC output voltage has dropped below the AC output voltage set points. Unit is still functioning, but if the low voltage does not self-corrected in 120 seconds the warning will become a fault.	Reduce AC load and verify battery input voltage. If adjustment of load level does not clear the warning, then no further action is required, warning is in place to prevent shutdown in the event of a quick, self-corrected issue.
<i>F11</i>	Fault	The <i>F11</i> Warning has persisted until it has become a fault.	Xantrex TR Series has shut down for safety reasons. Manually restart unit. If condition persists, contact Schneider Electric for service.
<i>F12</i>	Fault	At least one connected battery is bad (battery voltage has dropped below 8.5 V during charging).	Check all batteries and replace any faulty ones. Manually restart unit.
<i>F13</i>	Warning	The DC output voltage has risen above the DC output voltage set points. Unit is still functioning, but if the high voltage does not self-corrected in 30 seconds the warning will become a fault.	No action required, warning is in place to prevent shutdown in the event of a quick, self-corrected issue.

Table 3-1 Error Codes

Error Code	Fault or Warning	Description	Solution
F 13	Fault	The F 13 Warning has persisted until it has become a fault.	Xantrex TR Series has shut down for safety reasons. Manually restart unit. If condition persists, contact Schneider Electric for service.
F 14	Warning	At least one battery did not reach the target equalize set-point voltage during the 1 hour equalization stage. Normal inverting and charging is not affected by this warning.	Press the ON/STANDBY switch once to clear the fault. Check batteries and replace if necessary.

Table 3-2 Troubleshooting the Xantrex TR Series

Error Condition	Possible Cause	Solution
Xantrex TR Series will not turn on during initial power up.	Batteries are not connected, loose battery-side connections.	Check the batteries and cable connections.
No AC output voltage and no indicator lights ON.	Xantrex TR Series has been manually transitioned to OFF mode.	Press the ON/STANDBY switch to transition back to Invert Mode (only DC power present) or Charge Mode (AC and DC power present).
AC output voltage is low and the inverter turns loads ON and OFF.	Low battery.	Check the condition of the batteries and recharge if possible. Replace the batteries.
AC loads are receiving low voltage.	Loose AC output connections.	Check all AC output connections.
Inverter output reads incorrectly on volt meter.	Non-true RMS meter will probably not measure accurately.	Check the loads; if they are functioning correctly then meter reading is inaccurate. Use a true RMS meter for accurate reading if necessary.

Table 3-2 Troubleshooting the Xantrex TR Series

Error Condition	Possible Cause	Solution
Charger is inoperative and unit will not accept AC.	AC voltage has dropped out-of-tolerance Loose AC input connections. AC pass-through breaker on the side of the inverter is open.	Check the AC voltage for proper voltage and frequency (depending on model). See Appendix A, "Specifications". Check all AC output wiring connections. Reset AC pass-through breaker (see Figure 1-2 on page 1-4 for location).
Charger is supplying a lower charge rate.	Charger controls are improperly set. Low AC input voltage (120 Vac/230 Vac RMS required for full charger output). Loose or corroded battery connections. Loose AC input connections.	Refer to the section on adjusting the "Charger Rate". Repair or replace generator. Check and clean all DC connections. Check all AC output wiring connections.
Charge mode indicator light: - indicates charging, but no charge is going to the batteries. - is ON, but loads are not receiving power.	Charger AC input breaker on the side of the inverter is open. Open AC output breakers or fuses and AC wiring connections.	Reset charger AC input breaker (see Figure 1-2 on page 1-4 for location). If there is good AC voltage on inverter's AC output terminal block, then check for open AC output breakers or fuses and AC wiring connections.
Charger turns OFF while charging from a generator.	High AC input voltages from the generator.	Load the generator down with a heavy load. Turn the generator output voltage down.
Sensitive loads turn off temporarily when transferring between grid and inverting.	Inverter's 95 Vac/180 Vac transfer voltage may be too low to sustain certain loads. See Xantrex TR Series Inverter/Charger Installation Manual (Part #: 975-0367-01-01) and Appendix A, "Specifications".	Unit cannot serve as an uninterruptible power supply. Install a UPS if possible.

Problem Loads

The inverter can drive most loads, however, there are special conditions that can cause a load to behave differently than expected. The following describes some of the common problems encountered when using an inverter.



WARNING: Fire Hazard

Transformerless Battery Chargers are not to be used with any model of the Xantrex TR Series Inverter/Charger family. Connecting a transformerless battery charger could result in a overheating condition and possibly a fire.

Ceiling Fans	Most large diameter, slow turning fans run correctly, but generate more noise than when connected to utility power. High speed fans tend to operate normally.
Cell Phones	Some cellular telephones experience interference in the form of a clicking sound.
Computers and Sensitive Electronics	<p>Some computers and sophisticated electronics have power supplies that do not present a load until correct line voltage is available. When this occurs, each unit waits for the other to begin. This can usually be solved by plugging in an additional load (such as a lamp) to bring the inverter out of its search mode or by changing the search mode potentiometer to a lower set point or setting it to defeat.</p> <p>High starting surge for heavy loads will cause the inverter's output to dip during load start-up. Avoid using sensitive electronics, such as computers, during heavy load start-up.</p>
Consumer Electronics	<p>AM radios tend to pick up inverter noise, especially on the lower half of their band.</p> <p>High starting surge for heavy loads will cause the inverter's output to dip during load start-up. Avoid using sensitive electronics, such as computers, during heavy load start-up.</p>
Clocks	The inverter's crystal controlled oscillator keeps the frequency accurate to within a few seconds a day; however, external loads in the system may alter the inverter's output waveform causing clocks to run at different speeds. There may be periods where clocks keep time and then mysteriously do not. This is because most clocks do not draw enough power to trigger the load sensing circuit. In order to operate, especially with no other loads present, the inverter's load sensing circuit will have to be defeated. Refer to the Operation/Search Mode Watts.
Decreasing Loads	If the amount of power a load draws decreases after it has been switched on (such as with a small motor) and its current draw becomes less than the load sensing threshold, it will be turned alternately ON and OFF by the inverter. This can usually be solved by plugging in an additional load (such as a lamp).

Dimmer Switches	Most dimmer switches lose their ability to dim the lights when used with an inverter and operate only in the fully ON or OFF position. Newer, microprocessor controlled dimmers tend to work better in inverter applications.
Fluorescent Lights	Some devices cannot be detected by the inverter's load sensor and will not operate. Small fluorescent lights are the most common example. This can usually be solved by plugging in an additional load. Also, try turning the lamps AC plug over.
Heavy Loads	<p>If the battery bank cannot deliver the necessary amperage to drive a heavy load, the inverter will shut OFF. The battery voltage will then slowly rise back above the low voltage threshold causing the inverter to resume operation. As soon as the heavy load draws the batteries down, the cycle will continue unless the load is reduced or an additional source of power is added.</p> <p>High starting surge for heavy loads will cause the inverter's output to dip during load start-up. Avoid using sensitive electronics, such as computers, during heavy load start-up.</p>
Microwave Ovens	Microwave ovens are sensitive to peak output voltages. The higher the voltage, the faster they cook. Since the inverter's peak output voltage is dependent upon battery voltage and load size, the microwave's cook time may need to be increased.
Printers	Most inkjet type printers work well in inverter applications. Laser printers, however, require high current for their fusing circuit and are not recommended for use with an inverter.
Rechargeable Devices	When first using a rechargeable device, monitor its temperature for 10 minutes to ensure it does not become abnormally hot. Excessive heat will indicate that it is incompatible with the inverter.
Undersized Loads	If the power consumed by a device is less than the inverter's search mode circuitry threshold, it will not run. This can usually be solved by plugging in an additional load such as a 100 watt light bulb.



CAUTION: Equipment Damage

Some products can be damaged when used with modified sine-wave power. If in doubt, check with the product's manufacturer.

A

Specifications

Appendix A, "Specifications" contains information about the electrical, environmental and regulatory specifications of the Xantrex TR Series Inverter/Charger.

- Table A-1 provides the electrical specifications for the Xantrex TR Series Inverter/Charger (120 Vac/60 Hz. models).
- Table A-2 provides the electrical specifications for the Xantrex TR Series Inverter/Charger (230 Vac/50 Hz. models).
- Table A-3 provides physical and environmental specifications for all models of the Xantrex TR Series Inverter/Charger.
- Information is also provided on the safety and electromagnetic compatibility specifications for the Xantrex TR Series Inverter/Charger.

Specifications

Table A-1 Electrical Specifications^a - 120 Vac/60 Hz Models

Model	Xantrex TR1512 120 60	Xantrex TR2412 120 60	Xantrex TR1524 120 60	Xantrex TR2424 120 60	Xantrex TR3624 120 60
AC Nominal Input Voltage	120 Vac	120 Vac	120 Vac	120 Vac	120 Vac
Maximum AC Input Voltage	140 Vrms	140 Vrms	140 Vrms	140 Vrms	140 Vrms
AC Input Low Transfer Voltage (wide/narrow)	65/95 Vac	65/95 Vac	65/95 Vac	65/95 Vac	65/95 Vac
Frequency: ($\pm 0.04\%$ Crystal controlled)	60 Hz	60 Hz	60 Hz	60 Hz	60 Hz
Narrow Setting (Charge & Pass - through)	55—64 Hz	55—64 Hz	55—64 Hz	55—64 Hz	55—64 Hz
Wide Setting (Charge)	55—68 Hz	55—68 Hz	55—68 Hz	55—68 Hz	55—68 Hz
Wide Setting (Pass-through)	41—68 Hz	41—68 Hz	41—68 Hz	41—68 Hz	41—68 Hz
Maximum AC Input Current	50 Aac 30 Aac 20 Aac	60 Aac 30 Aac 30 Aac	50 Aac 30 Aac 20 Aac	60 Aac 30 Aac 30 Aac	60 Aac 30 Aac 30 Aac
Pass-through Charging					
Nominal AC Input Current ^b	40 Aac	48 Aac	40 Aac	48 Aac	48 Aac
Pass-through Charging	28 Aac 12 Aac	26 Aac 22 Aac	28 Aac 12 Aac	26 Aac 22 Aac	26 Aac 22 Aac
Continuous Power (@ 25°C)	1500 VA	2400 VA	1500 VA	2400 VA	3600 VA
AC Current at Max. Charge Rate ^c	11.20 Aac	15.81 Aac	10.20 Aac	19.68 Aac	19.53 Aac
Rated Output Current	12.5 amps AC	20 amps AC	12.5 amps AC	20 amps AC	30 amps AC
Typical Efficiency	90%	92%	92%	93%	94%
AC Output Voltage (rms)	120 Vac	120 Vac	120 Vac	120 Vac	120 Vac
Max. Output Overcurrent Protection	30 amps AC	30 amps AC	30 amps AC	30 amps AC	45 amps AC
Surge Capability/Max. Output and Duration:					
Overload 10 sec Rating	3000 VA	4800 VA	3000 VA	4800 VA	7200 VA
Short Circuit 10 sec Rating	50 \pm 5 Apk	80 \pm 8 Apk	50 \pm 5 Apk	80 \pm 8 Apk	120 \pm 12 Apk
DC Current at Rated Power	157 amps	252 amps	76 amps	120 amps	186 amps
DC Input Voltage (nominal) ^d	12.6 Vdc	12.6 Vdc	25.2 Vdc	25.2 Vdc	25.2 Vdc
DC Input Voltage Range	11.0—15.0 Vdc	11.0—15.0 Vdc	22.0—30.0 Vdc	22.0—30.0 Vdc	22.0—30.0 Vdc
DC Charger Rate (Adjustable) $\pm 6\%$	10 to 70 amps	14 to 100 amps	5 to 35 amps	10 to 70 amps	10 to 70 amps
Power Factor while Charging	0.88	0.89	0.88	0.92	0.93
Tare Loss	26 W	25 W	25 W	24 W	24 W
Common Specifications:					
Voltage Regulation (max.)	104—127 Vac				
Voltage Regulation (Typical)	108—125 Vac				
Waveform	modified sine wave				
Load Power Factor (allowed)	0.8 to 1.0 (leading or lagging)				

Table A-1 Electrical Specifications^a - 120 Vac/60 Hz Models

Model	Xantrex TR1512 120 60	Xantrex TR2412 120 60	Xantrex TR1524 120 60	Xantrex TR2424 120 60	Xantrex TR3624 120 60
Adjustable Load Sensing Range	5 watts minimum to 240 watts maximum				
Force Air Cooling	Variable speed fan				
Automatic Transfer Relay	30 amps maximum (non-continuous)				

a. Specifications subject to change without notice.

b. This is the minimum AC input current required, at nominal input voltage, to obtain full continuous rated pass-through and maximum battery charging while adhering to the 80% ampacity rule of North American electrical codes.

c. In bulk mode (at nominal input AC and nominal DC voltage).

d. Product may not meet voltage regulation specifications at other than "Input Nominal" at full-rated load.

Specifications

Table A-2 Electrical Specifications^a - 230 Vac/50 Hz Models

Model	Xantrex TR1512 230 50	Xantrex TR1524 230 50	Xantrex TR2424 230 50
AC Nominal Input Voltage	230 Vac	230 Vac	230 Vac
Maximum AC Input Voltage	253 Vrms	253 Vrms	253 Vrms
AC Input Low Transfer Voltage (wide/narrow)	120/180 Vac	120/180 Vac	120/180 Vac
Frequency: ($\pm 0.04\%$ Crystal controlled)	50 Hz	50 Hz	50 Hz
Narrow Setting (Charge & Pass - through)	45—55 Hz	45—55 Hz	45—55 Hz
Wide Setting (Charge)	45—68 Hz	45—68 Hz	45—68 Hz
Wide Setting (Pass-through)	41—68 Hz	41—68 Hz	41—68 Hz
Maximum AC Input Current	23 amps	23 amps	30 amps
Nominal AC Input Current	23 amps	23 amps	30 amps
Continuous Power (@ 25°C)	1500 VA	1500 VA	2400 VA
AC Current at Max. Charge Rate ^b	5.88 Aac	6.00 Aac	10.44 Aac
Rated Output Current	6.4 amps AC	6.4 amps AC	10.4 amps AC
Typical Efficiency	92%	91%	94%
AC Output Voltage (rms)	230 Vac	230 Vac	230 Vac
Max. Output Overcurrent Protection	15 amps AC	15 amps AC	15 amps AC
Surge Capability/Max. Output and Duration:			
Overload 10 sec Rating	3000 VA	3000 VA	4800 VA
Short Circuit 10 sec Rating	26.5 \pm 2.5 Apk	26.5 \pm 2.5 Apk	42 \pm 4 Apk
DC Current at Rated Power	158 amps	77 amps	121 amps
DC Input Voltage (nominal) ^c	12.6 Vdc	25.2 Vdc	25.2 Vdc
DC Input Voltage Range	11.0—15.0 Vdc	22.0—30.0 Vdc	22.0—30.0 Vdc
DC Charger Rate (Adjustable) $\pm 6\%$	0 to 70 amps	0 to 35 amps	0 to 70 amps
Power Factor while Charging	0.91	0.83	0.92
Tare Loss	23 W	21 W	22 W
Common Specifications:			
Voltage Regulation (max.)	$\pm 5\%$ (-12%, +5% Xantrex TR1512 230 50 only)		
Voltage Regulation (Typical)	$\pm 2.5\%$		
Waveform	modified sine wave		
Load Power Factor (allowed)	0.8 to 1.0 (leading or lagging)		
Adjustable Load Sensing Range	10 watts minimum to 480 watts maximum		
Force Air Cooling	Variable speed fan		
Automatic Transfer Relay	30 amps maximum (non-continuous)		

a. Specifications subject to change without notice.

b. In bulk mode (at nominal input AC and nominal DC voltage).

c. Product may not meet voltage regulation specifications at other than "Input Nominal" at full-rated load.

Table A-3 Environmental Specifications^a

Model	Xantrex TR1512 120 60	Xantrex TR2412 120 60	Xantrex TR1524 120 60	Xantrex TR2424 120 60	Xantrex TR3624 120 60	Xantrex TR1512 230 50	Xantrex TR1524 230 50	Xantrex TR2424 230 50
Xantrex TR Series only								
Dimensions ^b	8.5 in. W x 7.25 in. H x 21 in. L (216 mm W x 184 mm H x 546 mm L)							
Weight	40 lbs (18 kg)	42 lbs (19 kg)	40 lbs (18 kg)	45 lbs (20 kg)	45 lbs (20 kg)	42 lbs (19 kg)	42 lbs (19 kg)	42 lbs (19 kg)
Shipping/Packaging plus Xantrex TR Series								
Dimensions	12.4 in. W x 11.8 in. H x 26.6 in. L (315 mm W x 300 mm H x 675 mm L)							
Weight	50 lbs (22.7 kg)	52 lbs (23.6 kg)	50 lbs (22.7 kg)	55 lbs (24.9 kg)	55 lbs (24.9 kg)	52 lbs (23.6 kg)	52 lbs (23.6 kg)	52 lbs (23.6 kg)
Ambient Temp Range								
Rated Temperature Range	Invert Mode: 32 °F to 122 °F (0 °C to +50 °C)							
	Charge Mode: 32 °F to 104 °F (0 °C to +40 °C) 105 °F to 122 °F (+40.5 °C to +50 °C) 50% derating							
Storage	-67 °F to 167 °F (-55 °C to +75 °C)							
Altitude:								
Operating	15,000 feet (4570 m)							
Non-operating	50,000 feet (16800 m)							
Mounting	wall-mount with 16 in. (40.6 cm) mounting centers							

a.Specifications subject to change without notice.

b.Allows for hardware extensions such as mounting rails, DC terminals, and front panel controls.

Safety and Electromagnetic Compatibility Specifications

120 Vac/60 Hz Models	CSA 107.1 UL 1741 FCC Part 15B Class B Ind. Canada ICES-0003 Class B
230 Vac/50 Hz Models	EN50178 New EMC Directive 2004/108/EC

Warranty and Return Information

Warranty

What does this warranty cover and how long does it last? This Limited Warranty is provided by Xantrex Technology Inc. ("Xantrex") and covers defects in workmanship and materials in your Xantrex TR Series Inverter/Charger. This warranty period lasts for two (2) years from the date of purchase at the point of sale to you, the original end user customer, unless otherwise agreed in writing (the "Warranty Period"). You will be required to demonstrate proof of purchase to make warranty claims.

This Limited Warranty is transferable to subsequent owners but only for the unexpired portion of the Warranty Period. Subsequent owners also require original proof of purchase as described in "What proof of purchase is required?"





What will Xantrex do? During the Warranty Period Xantrex will, at its option, repair the product (if economically feasible) or replace the defective product free of charge, provided that you notify Xantrex of the product defect within the Warranty Period, and provided that Xantrex through inspection establishes the existence of such a defect and that it is covered by this Limited Warranty.

Xantrex will, at its option, use new and/or reconditioned parts in performing warranty repair and building replacement products. Xantrex reserves the right to use parts or products of original or improved design in the repair or replacement. If Xantrex repairs or replaces a product, its warranty continues for the remaining portion of the original Warranty Period or 90 days from the date of the return shipment to the customer, whichever is greater. All replaced products and all parts removed from repaired products become the property of Xantrex.

Xantrex covers both parts and labor necessary to repair the product, and return shipment to the customer via a Xantrex-selected non-expedited surface freight within the contiguous United States and Canada. Alaska, Hawaii and outside of the United States and Canada are excluded. Contact Xantrex Customer Service for details on freight policy for return shipments from excluded areas.

How do you get service? If your product requires troubleshooting or warranty service, contact your merchant. If you are unable to contact your merchant, or the merchant is unable to provide service, contact Xantrex directly at:

www.schneider-electric.com

			
North America	1 650 351 8237 1 866 519 1470	1 925 245 1022	re.techsupport@schneider-electric.com
La France	+0825012999		fr-re-techsupport@fr.schneider-electric.com
Deutschland	+49 (0) 180 575 6575	+49 (0) 2102 404 7101	solarservice@de.schneider-electric.com
España	+34 93 498 7466	+34 93 305 5026	re.techsupport@es.schneider-electric.com
L'Italia	+39 035 4151111	+39 035415 3200	IT-pronto-contatto@it.schneider-electric.com

For other country details please contact your local Schneider Electric Sales Representative or visit our website at: <http://www.schneider-electric.com/sites/corporate/en/support/operations/local-operations/local-operations.page>

Direct returns may be performed according to the Xantrex Return Material Authorization Policy described in your product manual. For some products, Xantrex maintains a network of regional Authorized Service Centers. Call Xantrex or check our website to see if your product can be repaired at one of these facilities.

What proof of purchase is required? In any warranty claim, dated proof of purchase must accompany the product and the product must not have been disassembled or modified without prior written authorization by Xantrex.

Proof of purchase may be in any one of the following forms:

- The dated purchase receipt from the original purchase of the product at point of sale to the end user; or
- The dated dealer invoice or purchase receipt showing original equipment manufacturer (OEM) status; or
- The dated invoice or purchase receipt showing the product exchanged under warranty.

What does this warranty not cover? Claims are limited to repair and replacement, or if in Xantrex's discretion that is not possible, reimbursement up to the purchase price paid for the product. Xantrex will be liable to you only for direct damages suffered by you and only up to a maximum amount equal to the purchase price of the product.

Warranty and Return Information

This Limited Warranty does not warrant uninterrupted or error-free operation of the product or cover normal wear and tear of the product or costs related to the removal, installation, or troubleshooting of the customer's electrical systems. This warranty does not apply to and Xantrex will not be responsible for any defect in or damage to:

- a) the product if it has been misused, neglected, improperly installed, physically damaged or altered, either internally or externally, or damaged from improper use or use in an unsuitable environment;
- b) the product if it has been subjected to fire, water, generalized corrosion, biological infestations, or input voltage that creates operating conditions beyond the maximum or minimum limits listed in the Xantrex product specifications including, but not limited to, high input voltage from generators and lightning strikes;
- c) the product if repairs have been done to it other than by Xantrex or its authorized service centers (hereafter "ASCs");
- d) the product if it is used as a component part of a product expressly warranted by another manufacturer;
- e) component parts or monitoring systems supplied by you or purchased by Xantrex at your direction for incorporation into the product;
- f) the product if its original identification (trade-mark, serial number) markings have been defaced, altered, or removed;
- g) the product if it is located outside of the country where it was purchased; and
- h) any consequential losses that are attributable to the product losing power whether by product malfunction, installation error or misuse.

Disclaimer

Product

THIS LIMITED WARRANTY IS THE SOLE AND EXCLUSIVE WARRANTY PROVIDED BY XANTREX IN CONNECTION WITH YOUR XANTREX PRODUCT AND IS, WHERE PERMITTED BY LAW, IN LIEU OF ALL OTHER WARRANTIES, CONDITIONS, GUARANTEES, REPRESENTATIONS, OBLIGATIONS AND LIABILITIES, EXPRESS OR IMPLIED, STATUTORY OR OTHERWISE IN CONNECTION WITH THE PRODUCT, HOWEVER ARISING (WHETHER BY CONTRACT, TORT, NEGLIGENCE, PRINCIPLES OF MANUFACTURER'S LIABILITY, OPERATION OF LAW, CONDUCT, STATEMENT OR OTHERWISE), INCLUDING WITHOUT RESTRICTION ANY IMPLIED WARRANTY OR CONDITION OF QUALITY, MERCHANTABILITY OR FITNESS FOR A PARTICULAR PURPOSE. ANY IMPLIED WARRANTY OF MERCHANTABILITY OR FITNESS FOR A PARTICULAR PURPOSE TO THE EXTENT REQUIRED UNDER APPLICABLE LAW TO APPLY TO THE PRODUCT SHALL BE LIMITED IN DURATION TO THE PERIOD STIPULATED UNDER THIS LIMITED WARRANTY.

IN NO EVENT WILL XANTREX BE LIABLE FOR: (A) ANY SPECIAL, INDIRECT, INCIDENTAL OR CONSEQUENTIAL DAMAGES, INCLUDING LOST PROFITS, LOST REVENUES, FAILURE TO REALIZE EXPECTED SAVINGS, OR OTHER COMMERCIAL OR ECONOMIC LOSSES OF ANY KIND, EVEN IF XANTREX HAS BEEN ADVISED, OR HAD REASON TO KNOW, OF THE POSSIBILITY OF SUCH DAMAGE; (B) ANY LIABILITY ARISING IN TORT, WHETHER OR NOT ARISING OUT OF XANTREX'S NEGLIGENCE, AND ALL LOSSES OR DAMAGES TO ANY PROPERTY OR FOR ANY PERSONAL INJURY OR ECONOMIC LOSS OR DAMAGE CAUSED BY THE CONNECTION OF A PRODUCT TO ANY OTHER DEVICE OR SYSTEM; AND (C) ANY DAMAGE OR INJURY ARISING FROM OR AS A RESULT OF MISUSE OR ABUSE, OR THE INCORRECT INSTALLATION, INTEGRATION OR OPERATION OF THE PRODUCT BY PERSONS NOT AUTHORIZED BY XANTREX.

CONSUMERS IN THE EUROPEAN UNION:

IF YOU ARE A CONSUMER (RATHER THAN A PURCHASER OF THE PRODUCT IN THE COURSE OF A BUSINESS) AND PURCHASED THE PRODUCT IN A MEMBER STATE OF THE EUROPEAN UNION, THIS LIMITED WARRANTY SHALL BE SUBJECT TO YOUR STATUTORY RIGHTS AS A CONSUMER UNDER THE EUROPEAN UNION PRODUCT WARRANTY DIRECTIVE 1999/44/EC AND AS SUCH DIRECTIVE HAS BEEN IMPLEMENTED IN THE EUROPEAN UNION MEMBER STATE WHERE YOU PURCHASED THE PRODUCT. FURTHER, WHILE THIS LIMITED WARRANTY GIVES YOU SPECIFIC LEGAL RIGHTS, YOU MAY HAVE OTHER RIGHTS WHICH MAY VARY FROM EU MEMBER STATE TO EU MEMBER STATE OR, IF YOU DID NOT PURCHASE THE PRODUCT IN AN EU MEMBER STATE, IN THE COUNTRY YOU PURCHASED THE PRODUCT WHICH MAY VARY FROM COUNTRY TO COUNTRY AND JURISDICTION TO JURISDICTION.

CONSUMERS IN THE REST OF THE WORLD:

Exclusions

If this product is a consumer product, federal law does not allow an exclusion of implied warranties. To the extent you are entitled to implied warranties under federal law, to the extent permitted by applicable law they are limited to the duration of this Limited Warranty. Some states, provinces and jurisdictions do not allow limitations or exclusions on implied warranties or on the duration of an implied warranty or on the limitation or exclusion of incidental or consequential damages, so the above limitation(s) or exclusion(s) may not apply to you. This Limited Warranty gives you specific legal rights. You may have other rights which may vary from state to state, province to province or jurisdiction to jurisdiction.

Return Material Authorization Policy

For those products that are not being repaired in the field and are being returned to Xantrex, before returning a product directly to Xantrex you must obtain a Return Material Authorization (RMA) number and the correct factory "Ship To" address. Products must also be shipped prepaid. Product shipments will be refused and returned at your expense if they are unauthorized, returned without an RMA number clearly marked on the outside of the shipping box, if they are shipped collect, or if they are shipped to the wrong location.

When you contact Xantrex to obtain service, please have your instruction manual ready for reference and be prepared to supply:

- The serial number of your product
- Information about the installation and use of the unit
- Information about the failure and/or reason for the return
- A copy of your dated proof of purchase

Record these details in "Information About Your System".

Return Procedure

Package the unit safely, preferably using the original box and packing materials. Please ensure that your product is shipped fully insured in the original packaging or equivalent. This warranty will not apply where the product is damaged due to improper packaging.

Include the following:

- The RMA number supplied by Xantrex Technology Inc. clearly marked on the outside of the box.
- A return address where the unit can be shipped. Post office boxes are not acceptable.
- A contact telephone number where you can be reached during work hours.
- A brief description of the problem.

Ship the unit prepaid to the address provided by your Xantrex customer service representative.

If you are returning a product from outside of the USA or Canada In addition to the above, you **MUST** include return freight funds and are fully responsible for all documents, duties, tariffs, and deposits.

If you are returning a product to a Xantrex Authorized Service Center (ASC) A Xantrex return material authorization (RMA) number is not required. However, you must contact the ASC prior to returning the product or presenting the unit to verify any return procedures that may apply to that particular facility and that the ASC repairs this particular Xantrex product.

Out of Warranty Service

If the warranty period for your product has expired, if the unit was damaged by misuse or incorrect installation, if other conditions of the warranty have not been met, or if no dated proof of purchase is available, your unit may be serviced or replaced for a flat fee.

To return your product for out of warranty service, contact Xantrex Customer Service for a Return Material Authorization (RMA) number and follow the other steps outlined in "Return Procedure".

Payment options such as credit card or money order will be explained by the Customer Service Representative. In cases where the minimum flat fee does not apply, as with incomplete units or units with excessive damage, an additional fee will be charged. If applicable, you will be contacted by Customer Service once your unit has been received.

Warranty and Return Information

Information About Your System

As soon as you open your Xantrex TR Series Inverter/Charger package, record the following information and be sure to keep your proof of purchase.





- Serial Number _____
- Product Number Xantrex TR1512 120 60, Xantrex TR2412 120 60,
Xantrex TR1524 120 60, Xantrex TR2424 120 60,
Xantrex TR3624 120 60, Xantrex TR1512 230 50,
Xantrex TR1524 230 50, Xantrex TR2424 230 50
- Purchased From _____
- Purchase Date _____

If you need to contact Customer Service, please record the following details before calling. This information will help our representatives give you better service.

- Type of installation _____
- Length of time inverter has been installed _____
- Battery/battery bank size _____
- Battery type (e.g. flooded, sealed gel cell, AGM) _____
- DC wiring size and length _____
- Alarm sounding? _____
- Description of indicators on front panel _____
- Appliances operating when problem occurred _____
- Description of problem _____

Schneider Electric

www.schneider-electric.com

			
North America	1 650 351 8237 1 866 519 1470	1 925 245 1022	re.techsupport@schneider-electric.com
La France	+0825012999		fr-re-techsupport@fr.schneider-electric.com
Deutschland	+49 (0) 180 575 6575	+49 (0) 2102 404 7101	solarservice@de.schneider-electric.com
España	+34 93 498 7466	+34 93 305 5026	re.techsupport@es.schneider-electric.com
L'Italia	+39 035 4151111	+39 035415 3200	IT-pronto-contatto@it.schneider-electric.com

For other country details please contact your local Schneider Electric Sales Representative or visit our website at:
<http://www.schneider-electric.com/sites/corporate/en/support/operations/local-operations/local-operations.page>